



# OPERATOR'S MANUAL REVISION

REVISION No.	PUBLICATION	PUBLICATION No.	PUBLICATION DATE
60297-14-2	GO, IGO, GSO, IGSO-480 Operators Manual	60297-14	July, 1973

The page(s) furnished herewith are intended either to replace, add to, or delete pages in the basic manual.

Previous revisions to this publication	This revision consists of:-
August 1976 ii 5-6, Added pages 5-7, 5-8, 5-9, 5-10, 5-11 8-2	July 1980 1-5 2-6, 2-7 3-10, 3-11, 3-13, 3-33, 3-34 4-3 8-1, 8-5

# OPERATOR'S MANUAL

LYCOMING  
GO-480, GSO-480, IGO-480  
and IGSO-480 SERIES  
AIRCRAFT ENGINES

2nd. Edition

July, 1973

Approved by F.A.A.

Part No. 60297-14

Printed in U.S.A.

# LYCOMING OPERATOR'S MANUAL

## ATTENTION

### OWNERS, OPERATORS, AND MAINTENANCE PERSONNEL

This operator's manual contains a description of the engine, its specifications, and detailed information on how to operate and maintain it. Such maintenance procedures that may be required in conjunction with periodic inspections are also included. This manual is intended for use by owners, pilots and maintenance personnel responsible for care of Lycoming powered aircraft. Modifications and repair procedures are contained in Lycoming overhaul manuals; maintenance personnel should refer to these for such procedures.

### SAFETY WARNING

*Neglecting to follow the operating instructions and to carry out periodic maintenance procedures can result in poor engine performance and power loss. Also, if power and speed limitations specified in this manual are exceeded, for any reason; damage to the engine and personal injury can happen. Consult your local FAA approved maintenance facility.*

### SERVICE BULLETINS, INSTRUCTIONS, AND LETTERS

Although the information contained in this manual is up-to-date at time of publication, users are urged to keep abreast of later information through Lycoming Service Bulletins, Instructions and Service Letters which are available from all Lycoming distributors or from the factory by subscription. Consult the latest edition of Service Letter No. L114 for subscription information.

### SPECIAL NOTE

*The illustrations, pictures and drawings shown in this publication are typical of the subject matter they portray; in no instance are they to be interpreted as examples of any specific engine, equipment or part thereof.*

# LYCOMING OPERATOR'S MANUAL

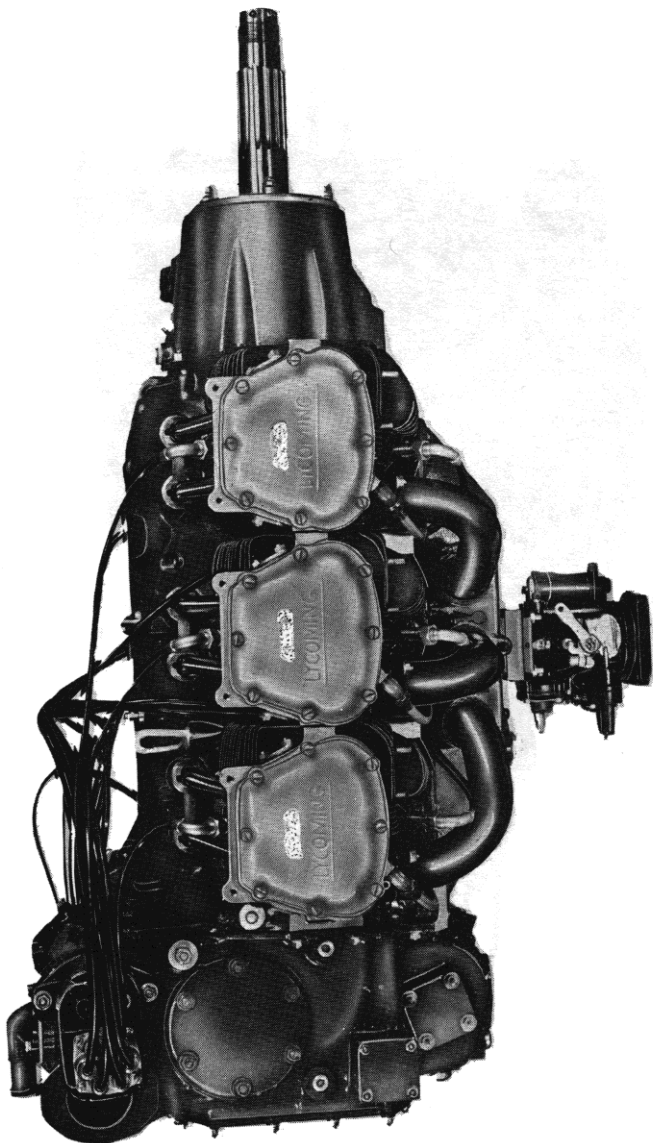

Right Side View - GO-480

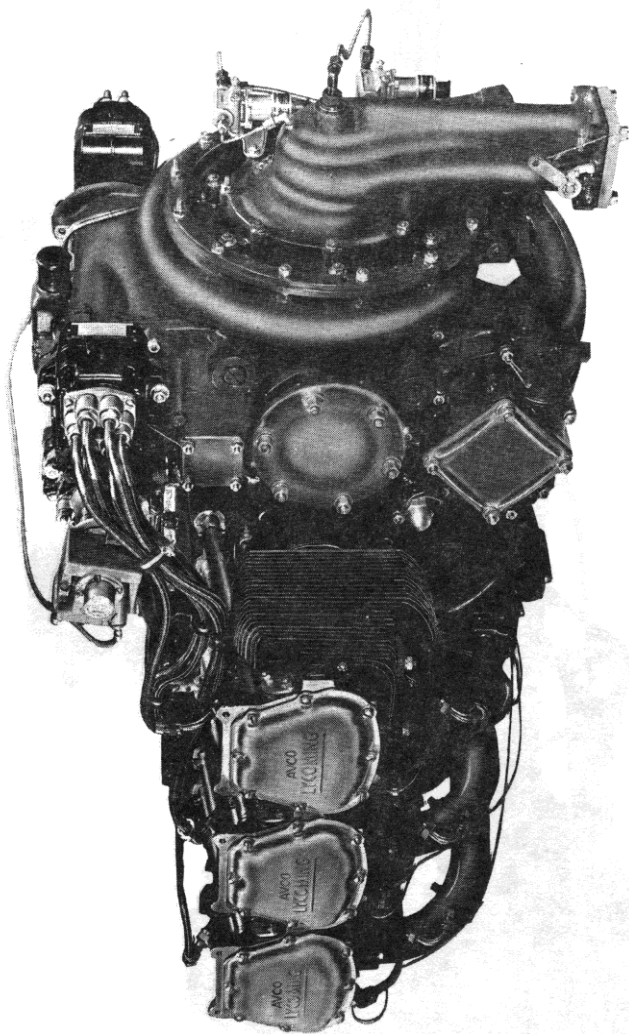

3/4 Rear View - IGSO-480

# TEXTRON LYCOMING OPERATOR'S MANUAL

## IMPORTANT SAFETY NOTICE

Proper service and repair is essential to increase the safe, reliable operation of all aircraft engines. The service procedures recommended by Textron Lycoming are effective methods for performing service operations. Some of these service operations require the use of tools specially designed for the task. These special tools must be used when and as recommended.

It is important to note that most Textron Lycoming publications contain various Warnings and Cautions which must be carefully read in order to minimize the risk of personal injury or the use of improper service methods that may damage the engine or render it unsafe.

It is also important to understand that these Warnings and Cautions are not all inclusive. Textron Lycoming could not possibly know, evaluate or advise the service trade of all conceivable ways in which service might be done or of the possible hazardous consequences that may be involved. Accordingly, anyone who uses a service procedure must first satisfy themselves thoroughly that neither their safety nor aircraft safety will be jeopardized by the service procedure they select.

**TEXTRON** Lycoming

## WARRANTY

(LIMITED)

NEW AND REMANUFACTURED  
RECIPROCATING AIRCRAFT ENGINE

### WHAT TEXTRON LYCOMING PROMISES YOU

Textron Lycoming warrants each new and remanufactured reciprocating engine sold by it to be free from defects in material and workmanship appearing within one (1) year from the date of first operation, excluding necessary aircraft acceptance testing. The date of first operation must not exceed two (2) years from the date of shipment from Textron Lycoming.

Textron Lycoming's obligation under this warranty shall be limited to its choice of repair or replacement, on an exchange basis, of the engine or any part of the engine, when Textron Lycoming has determined that the engine is defective in material or workmanship. Such repair or replacement will be made by Textron Lycoming at no charge to you. Textron Lycoming will also bear the cost for labor in connection with the repair or replacement as provided in Textron Lycoming's then current Removal and Installation Labor Allowance Guidebook.

In addition, if Textron Lycoming determines that the engine proves to be defective in material or workmanship during the period until the expiration of Textron Lycoming's recommended Time Between Overhaul (TBO), or two (2) years from the date of first operation, whichever occurs first, Textron Lycoming will reimburse you for a pro rata portion of the charge for the repair or replacement (at its choice) with Textron Lycoming parts, of parts required to be repaired or replaced, or a replacement engine, if it determines that engine replacement is required. Textron Lycoming's obligation during the proration period extends to major parts of the engine, which are limited to crankcase, crankshaft, camshaft, cylinders, connecting rods, pistons, sump, accessory housing and gears. The proration policy does not extend to labor or to accessories, including but not limited to magnetos, carburetors or fuel injectors, fuel pumps, starters, alternators and turbochargers and their controllers.

Any engine or part so repaired or replaced will be entitled to warranty for the remainder of the original warranty period.

### YOUR OBLIGATIONS

The engine must have received normal use and service. You must apply for warranty with an authorized Textron Lycoming distributor within 30 days of the appearance of the defect in material or workmanship.

Textron Lycoming's warranty does not cover normal maintenance expenses or consumable items. The obligations on the part of Textron Lycoming set forth above are your exclusive remedy and the exclusive liability of Textron Lycoming. This warranty allocates the risk of product failure between you and Textron Lycoming, as permitted by applicable law.

Textron Lycoming reserves the right to deny any warranty claim if it reasonably determines that the engine or part has been subject to accident or used, adjusted, altered, handled, maintained or stored other than as directed in your operator's manual, or if non-genuine Textron Lycoming parts are installed in or on the engine and are determined to be a possible cause of the incident for which the warranty application is filed.

Textron Lycoming may change the construction of engines at any time without incurring any obligation to incorporate such alterations in engines or parts previously sold.

THIS LIMITED WARRANTY IS EXCLUSIVE AND IN LIEU OF ALL OTHER WARRANTIES AND REPRESENTATIONS, EXPRESS OR IMPLIED OR STATUTORY, WHETHER WRITTEN OR ORAL, INCLUDING BUT NOT LIMITED TO ANY WARRANTY OF MERCHANTABILITY OR FITNESS FOR ANY PARTICULAR PURPOSE, AND ANY IMPLIED WARRANTY ARISING FROM ANY COURSE OF PERFORMANCE OR DEALING OR TRADE USAGE. THIS WARRANTY IS ALSO IN LIEU OF ANY OTHER OBLIGATION, LIABILITY, RIGHT OR CLAIM, WHETHER IN CONTRACT OR IN TORT, INCLUDING ANY RIGHT IN STRICT LIABILITY IN TORT OR ANY RIGHT ARISING FROM NEGLIGENCE ON THE PART OF TEXTRON LYCOMING, AND TEXTRON LYCOMING'S LIABILITY ON SUCH CLAIM SHALL IN NO CASE EXCEED THE PRICE ALLOCABLE TO THE ENGINE OR PART WHICH GIVES RISE TO THE CLAIM.

#### LIMITATION OF LIABILITY

IN NO EVENT, WHETHER AS A RESULT OF A BREACH OF WARRANTY, CONTRACT OR ALLEGED NEGLIGENCE, SHALL TEXTRON LYCOMING BE LIABLE FOR SPECIAL OR CONSEQUENTIAL OR ANY OTHER DAMAGES, INCLUDING BUT NOT LIMITED TO LOSS OF PROFITS OR REVENUES, LOSS OF USE OF THE ENGINE OR COST OF A REPLACEMENT.

No agreement varying this warranty or Textron Lycoming's obligations under it will be binding upon Textron Lycoming unless in writing signed by a duly authorized representative of Textron Lycoming.

*Effective October 1, 1995 Revision "J"*

*Textron Lycoming  
Williamsport, Pennsylvania*



**TEXTRON Lycoming**

## WARRANTY

(LIMITED)

REPLACEMENT PART - RECIPROCATING AIRCRAFT ENGINE

### WHAT TEXTRON LYCOMING PROMISES YOU

Textron Lycoming warrants each new reciprocating aircraft engine replacement part sold by it to be free from defects in material and workmanship appearing within one (1) year from its date of first operation. The date of first operation must not exceed two (2) years from the date of shipment from Textron Lycoming.

Textron Lycoming's obligation under this warranty shall be limited to its choice of repair or replacement, on an exchange basis, of the replacement part, when Textron Lycoming has determined that the part is defective in material or workmanship. Textron Lycoming will also reimburse you for the costs for labor in connection with the repair or replacement as provided in Textron Lycoming's then current Removal and Installation Labor Allowance Guidebook.

Any part so repaired or replaced will be warranted for the remainder of the original warranty period.

### YOUR OBLIGATIONS

The engine in which the replacement part is installed must have received normal use and service. You must apply for warranty with an authorized Textron Lycoming distributor within 30 days of the appearance of the defect in material or workmanship.

Textron Lycoming's warranty does not cover normal maintenance expenses or consumable items. The obligations on the part of Textron Lycoming set forth above are your exclusive remedy and the exclusive liability of Textron Lycoming. This warranty allocates the risk of product failure between you and Textron Lycoming, as permitted by applicable law.

Textron Lycoming reserves the right to deny any warranty claim if it reasonably determines that the engine or part has been subject to accident or used, adjusted, altered, handled, maintained or stored other than as directed in your operator's manual, or if non-genuine Textron Lycoming parts are installed in or on the engine and are determined to be a possible cause of the incident for which the warranty application is filed.

Textron Lycoming may change the construction of engines at any time without incurring any obligation to incorporate such alterations in engines or parts previously sold.

THIS LIMITED WARRANTY IS EXCLUSIVE AND IN LIEU OF ALL OTHER WARRANTIES AND REPRESENTATIONS, EXPRESS OR IMPLIED OR STATUTORY, WHETHER WRITTEN OR ORAL, INCLUDING BUT NOT LIMITED TO ANY WARRANTY OF MERCHANTABILITY OR FITNESS FOR ANY PARTICULAR PURPOSE, AND ANY IMPLIED WARRANTY ARISING FROM ANY COURSE OF PERFORMANCE OR DEALING OR TRADE USAGE. THIS WARRANTY IS ALSO IN LIEU OF ANY OTHER OBLIGATION, LIABILITY, RIGHT OR CLAIM, WHETHER IN CONTRACT OR IN TORT, INCLUDING ANY RIGHT IN STRICT LIABILITY IN TORT OR ANY RIGHT ARISING FROM NEGLIGENCE ON THE PART OF TEXTRON LYCOMING, AND TEXTRON LYCOMING'S LIABILITY ON SUCH CLAIM SHALL IN NO CASE EXCEED THE PRICE ALLOCABLE TO THE ENGINE OR PART WHICH GIVES RISE TO THE CLAIM.

LIMITATION OF LIABILITY

IN NO EVENT, WHETHER AS A RESULT OF A BREACH OF WARRANTY, CONTRACT OR ALLEGED NEGLIGENCE, SHALL TEXTRON LYCOMING BE LIABLE FOR SPECIAL OR CONSEQUENTIAL OR ANY OTHER DAMAGES, INCLUDING BUT NOT LIMITED TO LOSS OF PROFITS OR REVENUES, LOSS OF USE OF THE ENGINE OR COST OF A REPLACEMENT.

No agreement varying this warranty or Textron Lycoming's obligations under it will be binding upon Textron Lycoming unless in writing signed by a duly authorized representative of Textron Lycoming.

*Effective October 1, 1995 Revision "J"*

*Textron Lycoming  
Williamsport, Pennsylvania*

**TEXTRON Lycoming**

## WARRANTY

(LIMITED)  
OVERHAULED  
RECIPROCATING AIRCRAFT ENGINE

### WHAT TEXTRON LYCOMING PROMISES YOU

Textron Lycoming warrants each overhauled reciprocating engine sold by it to be free from defects in material and workmanship appearing within one (1) year from the date of first operation, excluding necessary aircraft acceptance testing. The date of first operation must not exceed two (2) years from the date of shipment from Textron Lycoming.

Textron Lycoming's obligation under this warranty shall be limited to its choice of repair or replacement, on an exchange basis, of the engine or any part of the engine, when Textron Lycoming has determined that the engine is defective in material or workmanship. Such repair or replacement will be made by Textron Lycoming at no charge to you. Textron Lycoming will also bear the cost for labor in connection with the repair or replacement as provided in Textron Lycoming's then current Removal and Installation Labor Allowance Guidebook.

Any engine or part so repaired or replaced will be entitled to warranty for the remainder of the original warranty period.

### YOUR OBLIGATIONS

The engine must have received normal use and service. You must apply for warranty with an authorized Textron Lycoming distributor within 30 days of the appearance of the defect in material or workmanship.

Textron Lycoming's warranty does not cover normal maintenance expenses or consumable items. The obligations on the part of Textron Lycoming set forth above are your exclusive remedy and the exclusive liability of Textron Lycoming. This warranty allocates the risk of product failure between you and Textron Lycoming, as permitted by applicable law.

Textron Lycoming reserves the right to deny any warranty claim if it reasonably determines that the engine or part has been subject to accident or used, adjusted, altered, handled, maintained or stored other than as directed in your operator's manual, or if non-genuine Textron Lycoming parts are installed in or on the engine and are determined to be a possible cause of the incident for which the warranty application is filed.

Textron Lycoming may change the construction of engines at any time without incurring any obligation to incorporate such alterations in engines or parts previously sold.

THIS LIMITED WARRANTY IS EXCLUSIVE AND IN LIEU OF ALL OTHER WARRANTIES AND REPRESENTATIONS, EXPRESS OR IMPLIED OR STATUTORY, WHETHER WRITTEN OR ORAL, INCLUDING BUT NOT LIMITED TO ANY WARRANTY OF MERCHANTABILITY OR FITNESS FOR ANY PARTICULAR PURPOSE AND ANY IMPLIED WARRANTY ARISING FROM ANY COURSE OF PERFORMANCE OR DEALING OR TRADE USAGE. THIS WARRANTY IS ALSO IN LIEU OF ANY OTHER OBLIGATION, LIABILITY, RIGHT OR CLAIM, WHETHER IN CONTRACT OR IN TORT, INCLUDING ANY RIGHT IN STRICT LIABILITY IN TORT OR ANY RIGHT ARISING FROM NEGLIGENCE ON THE PART OF TEXTRON LYCOMING, AND TEXTRON LYCOMING'S LIABILITY ON SUCH CLAIM SHALL IN NO CASE EXCEED THE PRICE ALLOCABLE TO THE ENGINE OR PART WHICH GIVES RISE TO THE CLAIM.

LIMITATION OF LIABILITY

IN NO EVENT, WHETHER AS A RESULT OF A BREACH OF WARRANTY, CONTRACT OR ALLEGED NEGLIGENCE, SHALL TEXTRON LYCOMING BE LIABLE FOR SPECIAL OR CONSEQUENTIAL OR ANY OTHER DAMAGES, INCLUDING BUT NOT LIMITED TO LOSS OF PROFITS OR REVENUES, LOSS OF USE OF THE ENGINE OR COST OF A REPLACEMENT.

No agreement varying this warranty or Textron Lycoming's obligations under it will be binding upon Textron Lycoming unless in writing signed by a duly authorized representative of Textron Lycoming.

*Effective October 1, 1995 Revision "J"*

*Textron Lycoming  
Williamsport, Pennsylvania*

# LYCOMING OPERATOR'S MANUAL

## TABLE OF CONTENTS

		Page
SECTION 1	DESCRIPTION	1-1
SECTION 2	SPECIFICATIONS	2-1
SECTION 3	OPERATING INSTRUCTIONS	3-1
SECTION 4	PERIODIC INSPECTIONS	4-1
SECTION 5	MAINTENANCE PROCEDURES	5-1
SECTION 6	TROUBLE--SHOOTING	6-1
SECTION 7	INSTALLATION	7-1
SECTION 8	TABLES	8-1

# LYCOMING OPERATOR'S MANUAL

## WARNING

*These engines are equipped with a dynamic counterweight system and must be operated accordingly. Avoid high engine speed, low manifold pressure operation. Use a smooth, steady movement of the throttle (avoid rapid opening or closing). If the warning is not heeded, there could be severe damage to the counterweights, roller and bushings.*

# LYCOMING OPERATOR'S MANUAL

## DESCRIPTION

	Page
General . . . . .	.1-1
Cylinders . . . . .	.1-1
Valve Operating Mechanism . . . . .	.1-1
Crankcase . . . . .	.1-1
Crankshaft . . . . .	.1-2
Connecting Rods . . . . .	.1-2
Pistons . . . . .	.1-2
Accessory Housing . . . . .	.1-2
Gears . . . . .	.1-2
Oil Sump (Dry) . . . . .	.1-2
Oil Sump (Wet) . . . . .	.1-2
Cooling System . . . . .	.1-2
Induction System . . . . .	.1-2
Lubrication System . . . . .	.1-3
Priming System . . . . .	.1-3
Ignition System . . . . .	.1-3

# LYCOMING OPERATOR'S MANUAL

GO-480, IGO-480, GSO-480, IGSO-480 SERIES SECTION 1

## SECTION 1

### DESCRIPTION

The GO-480, IGO-480, GSO-480 and IGSO-480 series are six cylinder, reduction gear driven, horizontally opposed, air cooled engines.

In referring to the location of the various engine components, the parts are described in their relationship to the engine as installed in the airframe. Thus, the power take-off end is considered the front and the accessory drive end the rear. The sump section is considered the bottom and the shroud tubes are located on the top. Reference to the left and right side is made with the observer facing the rear of the engine. The cylinders are numbered from front to rear, odd numbers on the right, even numbers on the left. The direction of rotation of the crankshaft, viewed from the rear, is clockwise. The direction of rotation for accessory drives is determined with the observer facing the drive pad.

**Cylinders** - The cylinders are of conventional air cooled construction with the head and barrel screwed and shrunk together. The heads are made from an aluminum alloy casting with a fully machined combustion chamber. Rocker shaft bearing supports are cast integral with the head. The cylinder barrels, which are machined from chrome nickel molybdenum steel forgings, have integral cooling fins and the inside of the barrels are ground to a specified finish.

**Valve Operating Mechanism** - A conventional type camshaft is located above and parallel to the crankshaft. The camshaft actuates hydraulic tappets which operate the valves through push rods and valve rockers. The valve rockers are supported on full floating steel shafts. The valve springs bear against hardened steel seats and are retained on the valve stems by means of split keys.

**Crankcase** - The crankcase assembly consists of two reinforced aluminum alloy castings, fastened together by studs, bolts and nuts. The mating surfaces of the two castings are joined without the use of a gasket, and the main bearing bores are machined for the use of precision type main bearing inserts.



# LYCOMING OPERATOR'S MANUAL

## SECTION 1 GO-480, IGO-480, GSO-480, IGSO-480 SERIES

***Crankshaft*** - The crankshaft is made from a nickel molybdenum steel forging. All bearing journal surfaces are nitrided. Freedom from torsional vibration is assured by a system of pendulum type dynamic counterweights.

***Connecting Rods*** - The connecting rods are made in the form of "H" sections from alloy steel forgings. They have replaceable bearing inserts in the crankshaft ends and bronze bushings in the piston ends. The bearing caps on the crankshaft ends are retained by two bolts and nuts through each cap.

***Pistons*** - The pistons are machined from an aluminum alloy forging. The piston pin is of a full floating type with a plug located in each end. Depending on the cylinder assembly, pistons may be machined for either three, four or five rings, and may employ either full wedge or half wedge rings. Consult the latest revision of Service Instruction No. 1037 for proper piston and ring combinations.

***Accessory Housing*** - The accessory housing is made from a magnesium casting and is fastened to the rear of the crankcase. It forms a housing for the oil pump and various accessory drives.

***Gears*** - The gears are of the conventional spur type and are precision machined.

***Oil Sump (Dry)*** - The oil sump incorporates a scavenge oil screen, oil drain plug, mounting for the carburetor or injector, intake riser and intake pipe mounting pad.

***Oil Sump (Wet)*** - The oil sump incorporates oil screen filters, carburetor or injector mounting pad, intake riser and intake pipe mounting pads.

***Cooling System*** - These engines are designed to be cooled by air pressure actuated by the forward speed of the aircraft. Baffles are provided to build up pressure and force the air through the cylinder fins. The air is then exhausted through gills or augmentor tubes usually located at the rear of the cowling.

***Induction System*** - Avco Lycoming GO-480, IGO-480, GSO-480 and IGSO-480 engines are equipped with either a Bendix-Stromberg carburetor, a Simmonds fuel injector or a Bendix fuel injector.

# LYCOMING OPERATOR'S MANUAL

## GO-480, IGO-480, GSO-480, IGSO-480 SERIES SECTION 1

The Bendix-Stromberg carburetor is of the single barrel type equipped with an automatic altitude mixture control unit and an airflow power enrichment valve. It is also equipped with a regulated pressure discharge nozzle, an idle cut-off mechanism and a single diaphragm vacuum operated accelerating pump.

The Simmonds injector is of the speed density type. This injector includes an altitude pressure compressor. A solenoid operated idle cut-off is provided. An emergency rich unit, which also incorporates a solenoid, allows 6.75 gallons of fuel per hour to flow to a second injection nozzle located just above the main nozzle.

The Bendix RS type fuel injection system operates by measuring the air-flow through the throttle body of the servo valve regulator control, and uses this measurement to operate a servo valve within the control. The accurately regulated fuel pressure established by the servo valve is used to control the distributor valve assembly, which then schedules fuel flow in proportion to air flow.

**Lubrication System** - The full pressure lubrication system is actuated by an impeller type pump.

**Priming System** - Provision for a primer system is provided on some engines.

**Ignition System** - Dual ignition is furnished by two magnetos. Consult Table 1 for model application.

# LYCOMING OPERATOR'S MANUAL

## SECTION 1 GO-480, IGO-480, GSO-480, IGSO-480 SERIES

### TABLE 1

MODEL APPLICATION			
Model	Magnetos		Fuel Injector or Carburetor
	Left	Right	
GO-480			
-B	S6LN-21	S6LN-20	PS-5BD
-B1A6	S6LN-21	S6LN-20	PS-5BD
-B1B	S6LN-51	S6LN-50	PS-5BD
-B1C	S6LN-21	S6LN-20	PS-5BD
-B1D	S6LN-21	S6LN-20	PS-5BD
-C1B6	S6RN-21	S6LN-20	PS-5BD
-C1D6	S6LN-21	S6LN-20	PS-5BD
-C2C6	S6LN-51	S6LN-50	PS-5BD
-C2D6	S6LN-21	S6LN-20	PS-5BD
-D1A	S6RN-21	S6LN-20	PS-5BD
-F6	S6LN-51	S6LN-50	PS-5BD
-F1A6	S6LN-21	S6LN-20	PS-5BD
-G1A6	S6LN-21	S6LN-20	PS-5BD
-G1B6	S6RN-21	S6LN-20	PS-5BD
-G1D6	S6LN-21	S6LN-20	PS-5BD
-G1E6	S6LN-200	S6LN-204	PS-5BD
-G1H6	S6LN-21	S6LN-20	PS-5BD
-G1J6	S6LN-1227	S6LN-1209	PS-5BD
-G2D6	S6LN-21	S6LN-20	PS-5BD
-G2F6	S6LN-200	S6LN-204	PS-5BD
GSO-480			
-A1A6	S6RN-21	S6LN-20	PSH-7BD
-B1A6	S6RN-21	S6LN-20	PS-7BD
-B1B3	S6RN-200	S6LN-204	PSH-7BD
-B1B6	S6RN-21	S6LN-20	PSH-7BD
-B1C6	S6RN-21	S6LN-20	PSH-7BD
-B1E6	S6RN-200	S6LN-204	PS-7BD
-B1F6	S6RN-200	S6LN-204	PSH-7BD
-B1G6	S6RN-200	S6LN-204	PSH-7BD
-B1J6	S6RN-1227	S6LN-1209	PS-7BD
-B2C6	S6RN-21	S6LN-20	PSH-7BD
-B2D6	S6RN-21	S6LN-20	PSD-7BD

**TABLE 1**

<b>MODEL APPLICATION</b>			
<b>Model</b>	<b>MAGNETO</b>		<b>Fuel Injector or Carburetor</b>
	<b>Left</b>	<b>Right</b>	
<b>GSO-480 (cont.)</b>			
-B2G6	S6RN-200	S6LN-204	PSH-7BD
-B2H6	S6RN-200	S6LN-204	PSD-7BD
<b>IGO-480</b>			
-A1A6	S6LN-1227	S6LN-1209	RSA-5AD1
-A1B6	S6LN-21	S6LN-20	RSA-5AD1
<b>IGSO-480</b>			
-A1A6	S6RN-21	S6LN-20	Type 570
-A1B6	S6RN-200	S6LN-204	Type 570
-A1C6	S6RN-21	S6LN-20	Type 570
-A1D6	S6RN-21	S6LN-20	RS10-FB1
-A1E6	S6RN-200	S6LN-204	RS10-FB1
-A1F6, -A1F3	S6RN-200	S6LN-204	Type 570
-A1G6	S6RN-1208	S6LN-1209	RS10-FB1

# LYCOMING OPERATOR'S MANUAL

## SPECIFICATIONS

	Page
<b>Specifications</b>	
GO-480-B, -D, -C1, -G1, -C2, -G2, -F Series . . . . .	.2-1
GSO-480, IGSO-480, IGO-480 Series . . . . .	.2-1
<b>Specifications - Accessory Drives</b>	
GO-480-B, -B1A6, -G1A6, -G1J6, IGO-480-A1A6, -A1B6 . . . . .	.2-2
GO-480-B1B, -B1D, -C1D6, -C2C6, -C2D6, -F6, -F1A6, -G1D6, -G2D6, -G2F6 . . . . .	.2-2
GO-480-B1C, -G1H6 . . . . .	.2-3
GO-480-D1A, -C1B6, -G1B6 . . . . .	.2-3
GSO-480-A, -B, IGSO-480-A . . . . .	.2-4
<b>Detail Weights . . . . .</b>	<b>.2-5</b>
<b>Dimensions, Inches . . . . .</b>	<b>.2-7</b>

# LYCOMING OPERATOR'S MANUAL

## GO-480, IGO-480, GSO-480, IGSO-480 SERIES SECTION 2

### SECTION 2

### SPECIFICATIONS

#### GO-480 SERIES

	-B, -D	-C1, -G1	-C2, -G2	-F
FAA Type Certificate	275	275	275	275
Take-off horsepower	270	295	295	275
Take-off speed, RPM	3400	3400	3400	3400
Rated horsepower	260	280	285	265
Rated speed, RPM	3000	3000	3100	3100
Bore, inches	5.125	5.125	5.125	5.125
Stroke, inches	3.875	3.875	3.875	3.875
Displacement cubic inches	479.7	479.7	479.7	479.7
Compression ratio	7.3:1	8.7:1	8.7:1	7.3:1
Firing order	145236	145236	145236	145236
Spark occurs degrees BTC	25	25	25	25
Valve rocker clearance				
(hydraulic tappets collapsed)	.028-.080	.028-.080	.028-.080	.028-.080
Propeller drive ratio	77:120	77:120	77:120	77:120
Propeller drive rotation (viewed from rear)	Clockwise	Clockwise	Clockwise	Clockwise

### SPECIFICATIONS

	GSO-480, IGSO-480	IGO-480
FAA Type Certificate	284	275
Take-off horsepower	340	295
Take-off speed, RPM	3400	3400
Rated horsepower	320	280
Rated speed, RPM	3200	3000
Bore, inches	5.125	5.125
Stroke, inches	3.875	3.875
Displacement cubic inches	479.7	479.7
Compression ratio	7.3:1	8.7:1
Firing order	145236	145236
Spark occurs degrees BTC	25	25
Valve rocker clearance		
(hydraulic tappets collapsed)	.028-.080	.028-.080
Propeller drive ratio	77:120	77:120
Propeller drive rotation (viewed from rear)	Clockwise	Clockwise

# LYCOMING OPERATOR'S MANUAL

## SECTION 2 GO-480, IGO-480, GSO-480, IGSO-480 SERIES

### SPECIFICATIONS

GO-480-B, -B1A6, -G1A6, -G1J6  
IGO-480-A1A6, -A1B6

Accessory Drive	Gear Ratio	*Direction of Rotation
Magneto (left)	1.500:1	Clockwise
Magneto (right)	1.500:1	Clockwise
Starter	1.000:1	Clockwise
Generator	2.577:1	Clockwise
Fuel Pump	1.000:1	Clockwise
Tachometer SAE**	.500:1	Clockwise
Tachometer** - AND-20005	.500:1	Counter-Clockwise
Vacuum Pump	1.333:1	Clockwise
Propeller Governor	.801:1	Clockwise

GO-480-B1B, -B1D, -C1D6, -C2C6, -C2D6,  
-F6, -F1A6, -G1D6, -G2D6, -G2F6

Accessory Drive	Gear Ratio	*Direction of Rotation
Magneto (left)	1.500:1	Clockwise
Magneto (right)	1.500:1	Clockwise
Starter	1.000:1	Clockwise
Generator	1.250:1	Clockwise
Fuel Pump	1.000:1	Clockwise
Tachometer**	.500:1	Clockwise
Tachometer** - AND-20005	.500:1	Counter-Clockwise
Vacuum Pump	1.333:1	Clockwise
Propeller Governor	.801:1	Clockwise

\* - Facing drive pad.

\*\* - Whichever is applicable.

# LYCOMING OPERATOR'S MANUAL

## GO-480, IGO-480, GSO-480, IGSO-480 SERIES SECTION 2

### SPECIFICATIONS

#### GO-480-B1C, -G1H6

Accessory Drive	Gear Ratio	*Direction of Rotation
Magneto (left)	1.500:1	Clockwise
Magneto (right)	1.500:1	Clockwise
Starter	1.000:1	Clockwise
Fuel Pump	1.000:1	Clockwise
Tachometer SAE	.500:1	Clockwise
Vacuum Pump	1.333:1	Clockwise
Propeller Governor	.801:1	Clockwise
Generator	2.569:1	Clockwise
Hydraulic Pump	1.250:1	Clockwise

#### GO-480-D1A, -C1B6, -G1B6

Accessory Drive	Gear Ratio	*Direction of Rotation
Magneto (left)	1.500:1	Counter-Clockwise
Magneto (right)	1.500:1	Clockwise
Starter	1.000:1	Clockwise
Generator	2.600:1	Clockwise
Fuel Pump	.803:1	Counter-Clockwise
Tachometer - AND-20005	.500:1	Counter-Clockwise
Vacuum Pump	1.219:1	Clockwise
Propeller Governor	.801:1	Clockwise
Hydraulic Pump	1.083:1	Clockwise

\* - Facing drive pad.



# LYCOMING OPERATOR'S MANUAL

## SECTION 2 GO-480, IGO-480, GSO-480, IGSO-480 SERIES

### SPECIFICATIONS

#### GSO-480-A

Accessory Drive	Gear Ratio	*Direction of Rotation
Magneto (left)	1.500:1	Counter-Clockwise
Magneto (right)	1.500:1	Clockwise
Starter	1.000:1	Clockwise
Generator	2.600:1	Clockwise
Fuel Pump	.803:1	Counter-Clockwise
Tachometer - AND-20005	.500:1	Counter-Clockwise
Vacuum Pump	1.083:1	Clockwise
Propeller Governor	.801:1	Clockwise
Hydraulic Pump	1.083:1	Clockwise

#### GSO-480-B, IGSO-480-A

Accessory Drive	Gear Ratio	*Direction of Rotation
Magneto (left)	1.500:1	Counter-Clockwise
Magneto (right)	1.500:1	Clockwise
Starter	1.000:1	Clockwise
Generator	2.600:1	Clockwise
Fuel Pump	.803:1	Counter-Clockwise
Tachometer - AND-20005	.500:1	Counter-Clockwise
Vacuum Pump	1.219:1	Clockwise
Propeller Governor	.801:1	Clockwise
Hydraulic Pump	1.083:1	Clockwise

\* - Facing drive pad.

**GO-480, IGO-480, GSO-480, IGSO-480 SERIES SECTION 2**

**DETAIL WEIGHTS**

*1. Engine, Standard, Dry Weight.*

Includes carburetor, magnetos, spark plugs, ignition harness and intercyylinder baffles.

MODEL	LBS.
GO-480-D1A . . . . .	454.00

Includes generator drive, starter drive, tachometer drive, propeller governor drive, carburetor, magnetos, spark plugs and ignition harness.

MODEL	LBS.
GO-480-F6 . . . . .	442.00
GO-480-F1A6 . . . . .	436.00

Includes propeller governor drive, generator drive, starter drive, tachometer drive, carburetor, magnetos, spark plugs, ignition harness and intercyylinder baffles.

MODEL	LBS.
GO-480-B, -B1A6, -B1D . . . . .	432.00
GO-480-B1B, -C1D6 . . . . .	438.00
GO-480-B1C . . . . .	435.00
GO-480-C1B6, -G1B6 . . . . .	464.00
GO-480-C2C6, -G1J6 . . . . .	448.00
GO-480-C2D6, -G1H6 . . . . .	442.00
GO-480-G2D6, -G2F6 . . . . .	442.00
GO-480-G1A6 . . . . .	446.00
GO-480-G1D6 . . . . .	444.00

Includes carburetor, magnetos, spark plugs, ignition harness and intercyylinder baffles.

MODEL	LBS.
GSO-480-A1A6 . . . . .	498.00



SECTION 2

GO-480, IGO-480, GSO-480, IGSO-480 SERIES

DETAIL WEIGHTS (CONT.)

MODEL	LBS.
GSO-480-B1E6, -B2H6	498.00
GSO-480-B1G6, -B2G6	497.00
GSO-480-B1F6	500.00
GSO-480-B1C6, -B2C6	512.00
GSO-480-B1A6, -B2D6	513.00
GSO-480-B1B6, -B1J6	515.00
GSO-480-B1B3	517.00
IGSO-480-A1A6, -A1B6, -A1D6, -A1E6	514.00
IGSO-480-A1C6, -A1F6	515.00
IGSO-480-A1F3, -A1G6	517.00

Includes shielded ignition and spark plugs, tachometer drive, propeller governor drive, fuel pump drive, starter and alternator drives, magneto, fuel injector and intercylinder baffles.

MODEL	LBS.
IGSO-480-A1B6	468.00

Includes shielded ignition and spark plugs, tachometer drive, propeller governor drive, fuel pump drive, starter and generator drives, magneto, fuel injector and intercylinder baffles.

MODEL	LBS.
IGO-480-A1A6	455.00

<b>DIMENSIONS, INCHES</b>			
<b>MODEL</b>	<b>HEIGHT</b>	<b>WIDTH</b>	<b>LENGTH</b>
<b>GO-480</b>			
-B, -B1A6, -B1D	28.02	33.12	38.64
-C1D6, -G1A6	28.02	33.12	38.64
-G1D6	28.02	33.12	38.64
-B1C, -G1H6	28.02	33.12	40.31
-B1B	28.02	33.12	41.62
-C1B6, -D1A, -G1B6	27.46	33.12	40.04
-C2C6	28.02	33.12	41.28
-C2D6	28.02	33.12	40.22
-F6	28.02	33.12	43.23
-F1A6, -G2D6	28.02	33.12	40.59
-G1J6	28.02	33.12	40.76
-G2F6	28.02	33.12	41.79
<b>IGO-480</b>			
-A1A6	28.02	33.12	40.76
-A1B6	28.02	33.12	38.64
<b>GSO-480</b>			
-A1A6	33.08	33.12	46.22
-B1A6, -B1E6	33.08	33.12	49.31
-B1J6	33.08	33.12	49.31
-B1B6, -B1F6	33.26	33.12	46.22
-B1C6, -B2C6	22.56	33.12	52.18
-B1G6, -B2G6	22.56	33.12	52.18
-B2D6, -B2H6	22.56	33.12	47.06
<b>IGSO-480</b>			
-A1A6, -A1B6	22.81	33.12	47.56
-A1C6, -A1F3, -A1F6	22.81	33.12	47.56
-A1D6	31.49	33.12	49.45
-A1E6, -A1G6	31.05	33.12	47.27

# LYCOMING OPERATOR'S MANUAL

## OPERATING INSTRUCTIONS

	Page
General . . . . .	3-1
Prestarting Items of Maintenance . . . . .	3-2
Starting Procedures . . . . .	3-2
Cold Weather Starting . . . . .	3-3
Ground Running and Warm-Up . . . . .	3-3
Ground Check . . . . .	3-4
Operation in Flight . . . . .	3-5
Engine Flight Chart . . . . .	3-10
Operating Conditions . . . . .	3-12
Shut-Down Procedure . . . . .	3-13
Performance Curves . . . . .	3-14

# LYCOMING OPERATOR'S MANUAL

GO-480, IGO-480, GSO-480, IGSO-480 SERIES SECTION 3

## SECTION 3

### OPERATING INSTRUCTIONS

**1. GENERAL.** Close adherence to these instructions will greatly contribute to the long life, economy and satisfactory operation of the engine.

#### *NOTE*

***YOUR ATTENTION IS DIRECTED TO THE WARRANTIES THAT APPEAR IN THE FRONT OF THIS MANUAL REGARDING ENGINE SPEED, THE USE OF SPECIFIED FUEL AND LUBRICANTS, REPAIRS AND ALTERATIONS. PERHAPS NO OTHER ITEM OF ENGINE OPERATION AND MAINTENANCE CONTRIBUTES QUITE SO MUCH TO SATISFACTORY PERFORMANCE AND LONG LIFE AS THE CONSTANT USE OF CORRECT GRADES OF FUEL AND OIL, CORRECT ENGINE TIMING AND FLYING THE AIRCRAFT AT ALL TIMES WITHIN THE SPEED AND POWER RANGE SPECIFIED FOR THE ENGINE. DO NOT FORGET THAT VIOLATION OF THE OPERATION AND MAINTENANCE SPECIFICATIONS FOR YOUR ENGINE WILL NOT ONLY VOID YOUR WARRANTY, BUT WILL SHORTEN THE LIFE OF YOUR ENGINE AFTER ITS WARRANTY PERIOD HAS PASSED.***

New engines have been carefully run-in by Avco Lycoming and therefore, no further break-in is necessary insofar as operation is concerned; however, new or newly overhauled engines should be operated using only the lubricating oils recommended in the latest edition of Service Instruction No. 1014.

The minimum fuel octane rating is listed in the flight chart, Part 8 of this section. Under no circumstances should fuel of a lower octane rating or automotive fuel (regardless of octane rating) be used.

# LYCOMING OPERATOR'S MANUAL

## SECTION 3 GO-480, IGO-480, GSO-480, IGSO-480 SERIES

**2. PRESTARTING ITEMS OF MAINTENANCE.** Before starting the aircraft engine for the first flight of the day, there are several items of maintenance inspection that should be performed. These are described in the Section 4 under Daily Pre-Flight Inspection. They must be observed before the engine is started.

### **3. STARTING PROCEDURES.**

- a. Perform pre-flight inspection.
- b. Set carburetor heat control in "cold" position.
- c. Set propeller governor control lever in "increase RPM" position.
- d. (Pressure carburetors and Bendix Injectors) Set mixture control on "Idle Cut-Off". (Simmonds Injector - "Idle Cut-Off" - "On".)
- e. Turn fuel valve to "on" position.
- f. Turn on fuel boost pump if aircraft is so equipped.
- g. Set throttle to 1/4 open position.
- h. Hold the engine primer switch to "on" for several seconds, or prime with one to three strokes of priming pump, depending on how aircraft is equipped.
- i. Set magneto selector switch. Consult airframe manufacturer's handbook for correct position.
- j. Engage starter.
- k. When the engine begins to fire, move mixture control into full rich position. (Pressure carburetors and Bendix Injectors.)

# LYCOMING OPERATOR'S MANUAL

GO-480, IGO-480, GSO-480, IGSO-480 SERIES SECTION 3

## CAUTION

*If engine fails to start immediately, return mixture control to "Idle Cut-Off" position. Failure to do so will create an excessive amount of fuel in the carburetor air scoop, constituting a fire hazard.*

- l. When engine starts, place magneto selectro switch in "Both" position.
- m. Check oil pressure gage for indicated pressure. If oil pressure is not indicated within thirty seconds, stop engine and determine trouble.

## NOTE

*If engine fails to achieve a normal start, assume it to be flooded and use standard clearing procedure. Then repeat above steps.*

**4. COLD WEATHER STARTING.** During extreme cold weather, it may be necessary to preheat the engine and oil before starting.

**5. GROUND RUNNING AND WARM-UP.** Subject engines are air pressure cooled and depend on the forward movement of the airplane to maintain proper cooling. Particular care is necessary, therefore, when operating these engines on the ground. To prevent overheating, it is recommended that the following precautions be observed.

- a. Head the aircraft into the wind.
- b. Leave mixture in "Full Rich".
- c. Operate the engine on the ground only with the propeller in minimum blade angle setting.
- d. Warm up at approximately 1000-1300 RPM. Avoid prolonged idling and do not exceed 2200 RPM on the ground.
- e. Engine is warm enough for take-off when the throttle can be opened without the engine faltering.



# LYCOMING OPERATOR'S MANUAL

## SECTION 3 GO-480, IGO-480, GSO-480, IGSO-480 SERIES

### 6. GROUND CHECK.

- a. Warm up engine as directed above.
- b. Check both oil pressure and oil temperature.
- c. Leave mixture on "Full Rich".
- d. Move the propeller control through its complete range to check operation and return to full low pitch position. Full feathering check on the ground is not recommended, but the feathering action can be checked by running the engine between 1500-1700 RPM and momentarily pulling the propeller control into the feathering position. Do not allow the engine speed to drop below 1000 RPM.
- e. A proper magneto check is important. Additional factors other than the ignition system, affect magneto drop-off. They are load-power output, propeller pitch and mixture strength. The important thing is that the engine runs smoothly, because magneto drop-off is affected by the variables listed above. Make the magneto check in accordance with the following procedures.

(1) With propeller in minimum pitch angle, set the engine to produce 50-65% power as indicated by manifold pressure gage. Mixture control should be in the "Full Rich" position. At these settings, the ignition system and spark plugs must work harder because of the greater pressure within the cylinders. Any existing ignition problems will be apparent under these conditions. Mag checks at low power settings will only indicate fuel-air distribution quality.

(2) Switch from both magnetos to one and note drop-off. Return to both until engine regains speed and switch to the other magneto and note drop-off. Then return to normal operation. Normal drop-off is 100 RPM. Drop-off should not exceed 175 RPM, and the difference between drop-off of both magnetos should not exceed 50 RPM. A smooth drop-off past normal is usually a sign of a too lean or too rich mixture.

(3) Do not operate on a single magneto for too long a period; 2 or 3 seconds is usually sufficient to check drop-off. This will minimize plug fouling.

# LYCOMING OPERATOR'S MANUAL

GO-480, IGO-480, GSO-480, IGSO-480 SERIES SECTION 3

## 7. OPERATION IN FLIGHT.

### a. Take-Off and Climb.

(1) Limit take-off and climb to five minutes at 3400 RPM. Supercharged engines never exceed 48 in. manifold pressure at 3400 RPM.

#### NOTE

*Although take-off power may be used for a maximum of five minutes, it is advisable to throttle back to rated power as soon as take-off obstacles have been cleared, as take-off power is intended to be used in emergencies only.*

(2) *Supercharged Engines Equipped with Simmonds Fuel Injectors* - The emergency rich fuel supply is to be used only in two engine continuous climb, full throttle operation above 15,000 feet, and when cylinder head temperatures exceed 435°F. (224°C.).

### (3) Leaning Fuel/Air Mixture -

(a) (All subject engines except IGSO-480-A1D6, -A1E6, -A1G6.) These engines are equipped with either pressure carburetors or automatically controlled fuel systems and manual leaning is not recommended.

(b) (IGSO-480-A1D6, -A1E6, -A1G6.) The manual mixture control should remain in the full rich position. However, during take-off from high elevation airports or during climb if loss of power results from over-richness; adjust mixture control only enough to obtain smooth operation.

### b. Continuous Cruise Operation -

(1) *Supercharged engines* - Never exceed 45 inches manifold pressure at rated speed (3200 RPM).

(2) When increasing power, first increase the RPM with propeller governor, then increase manifold pressure with throttle. When decreasing power, throttle back to desired manifold pressure, then change propeller governor to desired RPM.

# LYCOMING OPERATOR'S MANUAL

GO-480, IGO-480, GSO-480, IGSO-480 SERIES SECTION 3

## NOTE

*These are high out-put engines demanding smooth operation of the throttle to avoid detuning the counterweights. Avoid rapid opening or closing of the throttle and high RPM, low manifold pressure settings.*

(3) *Cruise Power Settings* - Consult the airframe manufacturer's handbook for manifold pressure and RPM for various power settings.

(4) *Manual Leaning Procedures* - All subject engines except IGSO-480-A1D6, -A1E6, -A1G6 are equipped with either a pressure carburetor or an automatically controlled fuel system and manual leaning is not recommended.

(IGSO-480-A1D6, -A1E6, -A1G6.) The manual mixture control should remain in the full-rich position unless the aircraft is equipped with either an approved fuel flow meter or an exhaust gas temperature gage. The recommended leaning procedures are as follows:

## LEANING PRECAUTIONS

*Never exceed the specified maximum cylinder head temperature.*

*For continuous cruise operation, for best service life of the engine, maintain cylinder head temperatures below 435°F. (224°C.).*

*Do not manually lean engines equipped with pressure carburetors or automatically controlled fuel systems.*

*Always enrich mixture before increasing power.*

(a) Equipped with an Approved Fuel Flow Meter.

Lean in accordance with power/fuel flow curve.

(b) Equipped with an Exhaust Gas Temperature Gage.

(75% Power Cruise.) Never lean beyond 150°F. on rich side of peak EGT. Monitor cylinder head temperatures.

(65% Power and below.) Operate at peak EGT, or if desired, drop 50° on rich side of peak EGT.

# LYCOMING OPERATOR'S MANUAL

## GO-480, IGO-480, GSO-480, IGSO-480 SERIES SECTION 3

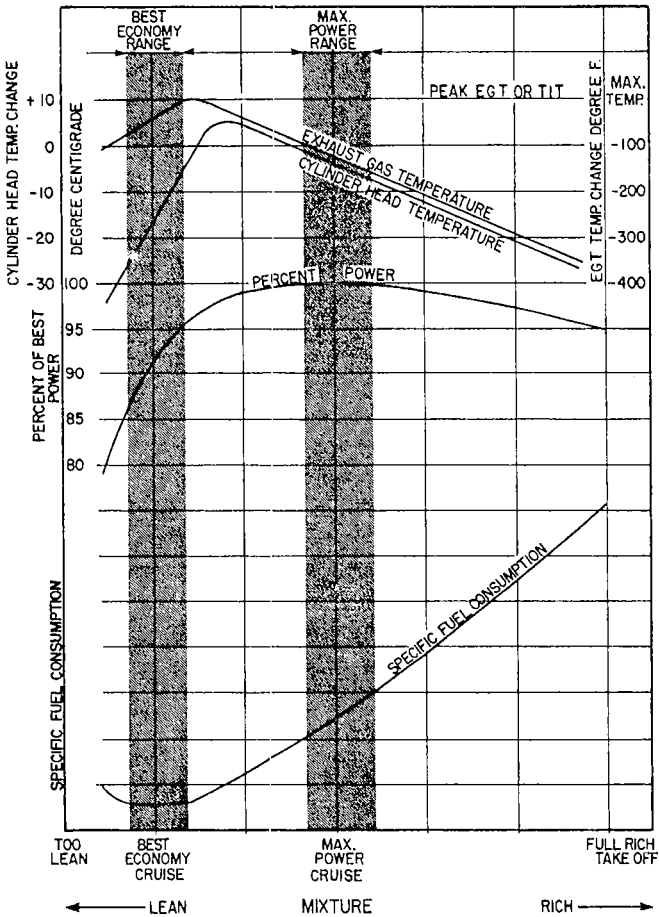

Figure 3-1. Representative Effect of Fuel/Air Ratio on Cylinder Head Temperature, Power and Specific Fuel Consumption at Constant RPM Cruise Range Operation

# LYCOMING OPERATOR'S MANUAL

## SECTION 3 GO-480, IGO-480, GSO-480, IGSO-480 SERIES

*d. Use of Carburetor Heat Control* - Under certain moist atmospheric conditions it is possible for ice to form in the induction system even in summer weather. This is due to the high air velocity through the carburetor venturi and the absorption of heat from this air by evaporation of the fuel. The temperature in the mixture chamber may drop 20°F. to 70°F. below the temperature of the incoming air. If this air contains a large amount of moisture, the cooling process will cause precipitation in the form of ice. These ice formations generally begin in the vicinity of the butterfly and will often build up to such an extent that a drop in power output results. This loss of power is reflected by a drop in manifold pressure. If not detected, this condition will continue to such an extent that the reduced power will cause complete engine stoppage.

To avoid this condition, all installations are equipped with a system for preheating the incoming air supply to the carburetor. In this way, sufficient heat is added to replace the heat loss to vaporization of fuel; and the mixing chamber's temperature cannot drop to the freezing point of water. This air preheater is essentially a tube or jacket through which the exhaust pipe from one or more cylinders is passed, and the air flowing over these surfaces is raised to the required temperature before entering the carburetor. Consistently high temperatures are to be avoided because of a loss in power and a decided variation of the mixture. High charge temperatures also favor detonation and preignition, both of which are to be avoided if normal service life is to be expected from the engine. The following outline is the proper method of utilizing the carburetor heat control.

*(1) Take-off* - Take-off should be made with carburetor heat in full cold position. The possibility of icing at wide throttle opening is very remote.

(2) *Flight Operation* - The carburetor air heat control should be left in the cold position during normal flight operations. On damp, cloudy, foggy or hazy days, regardless of outside temperature, keep a sharp lookout for loss of power. This loss of power will be shown by unaccountable loss in manifold pressure. When this situation arises, apply full carburetor air heat and open the throttle to limiting manifold pressure. This will result in a slight additional drop in manifold pressure which is normal, and this drop will be regained as the ice is melted out of the induction system. When the ice has been melted from the induction system the carburetor heat control should be returned to the cold position. In those aircraft equipped with a carburetor air temperature gage, partial heat may be used to keep the mixture temperature above the freezing point (32°F.).

#### **WARNING**

*Caution must be exercised when operating with partial heat on aircraft that do not have a carburetor air temperature gage. Moisture in crystal form that would ordinarily pass through the induction system, can be raised in temperature by use of partial heat to the point where the crystals are melted into liquid form. This moisture can form carburetor ice due to the temperature drop as it passes through the venturi of the carburetor. It is advisable, therefore, to use either full heat or no heat in aircraft that are not equipped with a carburetor air temperature gage.*

(3) *Landing Approach* - In making an approach for a landing, carburetor air heat should generally be in the "Full Cold" position. However, if icing conditions are suspected, the "Full Heat" should be applied. In the case that full power need be applied under these conditions, as for an aborted landing, the carburetor heat should be returned to "Full Cold" after full power application. See the aircraft flight manual for specific instructions.

**SECTION 3 GO-480, IGO-480, GSO-480, IGSO-480 SERIES**

**& ENGINE FLIGHT CHART.**

**Fuel and Oil -**

Model	Aviation Grade Fuel
GO-480-B,-D & -F Series	80/87 octane (minimum)
GO-480-C, -G Series; IGO-480	100/130 octane (minimum)
GSO-480 Series and IGSO-480 Series	100/130 octane (minimum)

**ALL MODELS**

Average Ambient Air	*Recommended Grade Oil	
	MIL-L-6082 Grades	MIL-L-22851 Ashless Dispersant Grades
Above 80°F. (26.66°C.)**	SAE 60**	SAE 60**
Above 60°F. (15.55°C.)	SAE 50	SAE 40 or SAE 50
30° (-1.11°C.) to 90°F. (32.22°C.)	SAE 40	SAE 40
0° (-17.77°C.) to 70°F. (21.11°C.)	SAE 30	SAE 30 or SAE 40
Below 10°F. (-12.22°C.)	SAE 20	SAE 20

\* - Refer to the latest edition of Service Instruction No. 1014.

\*\* - Applies to IGSO-480-A1A6, -A1B6, -A1C6, -A1F3, -A1F6 only.

**OIL SUMP CAPACITY (Wet Sump Engines)**

All Subject Engines . . . . .	12 U. S. Quarts
Minimum Safe Quantity in Sump . . . . .	2-3/4 U. S. Quarts

**OPERATING CONDITIONS**

**GO-480-G, IGO-480, GSO-480-B and IGSO-480-A1D6, -A2E6, -A1G6 Series**

Average Ambient Air	Desired	Maximum
Above 80°F. (26.6°C.)	200°F. (93.3°C.)	235°F. (112.77°C.)
Above 60°F. (15.5°C.)	180°F. (82°C.)	235°F. (112.77°C.)
30°F. (-1.1°C.) to 90°F. (32.2°C.)	180°F. (82°C.)	235°F. (112.77°C.)
0°F. (-17.7°C.) to 70°F. (21.1°C.)	180°F. (82°C.)	235°F. (112.77°C.)
Below 10°F. (12.2°C.)	170°F. (76.6°C.)	210°F. (98.88°C.)

# AVCO LYCOMING OPERATOR'S MANUAL

GO-480, IGO-480, GSO-480, IGSO-480 SERIES

SECTION 3

IGSO-480-A1A6, -A1B6, -A1C6, -A1F3, -A1F6 Series

Average Ambient Air	Desired	Maximum
Above 80°F. (26.6°C.)	200°F. (93.3°C.)	245°F. (118.33°C.)
Above 60°F. (15.5°C.)	180°F. (82°C.)	245°F. (118.33°C.)
30°F. (-1.11°C.) to 90°F. (32.2°C.)	180°F. (82°C.)	245°F. (118.33°C.)
0°F. (-17.7°C.) to 70°F. (21.1°C.)	180°F. (82°C.)	245°F. (118.33°C.)
Below 10°F. (12.2°C.)	170°F. (76.6°C.)	245°F. (118.33°C.)

Oil Pressure, psi	Maximum	Minimum	Idling
Normal Operating All models except IGSO-480-A1A6, -A1B6, -A1F3, -A1F6, -A1G6	85	65	25
IGSO-480-A1G6	85	55	25
IGSO-480-A1A6, -A1B6, -A1F3, -A1F6	85	55	35

Fuel Inlet Pressure, psi	Maximum	Minimum
All GO-480; GSO-480; IGSO-480-A1A6, -A1B6, -A1C6, -A1F3, -A1F6	15	9
IGSO-480-A1D6, -A1E6	35	17
IGSO-480-A1G6	65	17
IGO-480-A1A6, -A1B6	45	16

Revised July, 1980

3-11



**SECTION 3 GO-480, IGO-480, GSO-480, IGSO-480 SERIES**
**OPERATING CONDITIONS**
**GO-480-B, -D1A Series**

Operation	RPM	HP	Fuel Cons. Gal./Hr.	Max. Oil Cons. Qts./Hr.	Max. Cyl. Head Temp.
Normal Rated	3000	260	-----	1.4	475°F.
Performance Cruise (75% Rated Power)	2750	195	19.0	1.1	475°F.
Economy Cruise (65% Rated Power)	2600	170	15.0	0.9	475°F.

**GO-480-C1B6, -C1D6, -G1A6, -G1D6, -G1J6, -G1B6, -G1H6**

Normal Rated	3000	280	-----	1.6	475°F.
Performance Cruise (75% Rated Power)	2750	210	18.5	1.2	475°F.
Economy Cruise (65% Rated Power)	2600	180	14.5	1.0	475°F.

**GO-480-C2C6, -C2D6, -G2D6, -G2F6**

Normal Rated	3100	285	-----	1.6	475°F.
Performance Cruise (75% Rated Power)	2750	214	21.0	1.2	475°F.
Economy Cruise (65% Rated Power)	2600	185	17.0	1.0	475°F.

**GO-480-F Series**

Normal Rated	3100	265	-----	1.5	475°F.
Performance Cruise (75% Rated Power)	2750	199	21.0	1.1	475°F.
Economy Cruise (65% Rated Power)	2600	172	17.0	1.0	475°F.



## OPERATING CONDITIONS (CONT.)

## IGO-480-A1A6

Operation	RPM	HP	Fuel Cons. Gal./Hr.	Max. Oil Cons. Qts./Hr.	Max. Cyl. Head Temp.
Normal Rated	3000	280	-----	1.6	475°F.
Performance Cruise (75% Rated Power)	2750	210	16.0	1.2	475°F.
Economy Cruise (65% Rated Power)	2600	180	13.0	1.0	475°F.

## IGO-480-A1B6

Normal Rated	3000	280	-----	1.15	475°F.
Performance Cruise (75% Rated Power)	2750	210	16.0	.7	475°F.
Economy Cruise (65% Rated Power)	2600	180	13.0	.6	475°F.

## GSO-480\*

Normal Rated	3200	320	-----	1.8	475°F.
Performance Cruise (75% Rated Power)	2750	240	22.0	1.3	475°F.
Economy Cruise (65% Rated Power)	2600	208	17.0	1.2	475°F.

\* - Never exceed 48 inches of manifold pressure (3400 RPM) for take-off or 45 inches of manifold pressure (3200) for normal rated power. At critical altitude, 43.3 inches is maximum manifold pressure for normal rated power.

## IGSO-480\*

Normal Rated	3200	320	-----	1.42	475°F.
Performance Cruise (75% Rated Power)	2750	240	20.0	.80	475°F.
Economy Cruise (65% Rated Power)	2600	208	17.5	.693	475°F.

\* - Never exceed 48 inches of manifold pressure (3400 RPM) for take-off or 45 inches of manifold pressure (3200) for normal rated power. At critical altitude, 41.5 inches is maximum manifold pressure for normal rated power.

*e. Engine Shut-Down -*

- (1) Set propeller at minimum blade angle.
- (2) Idle until there is a decided decrease in cylinder head temperatures.
- (3) Move mixture control to "Idle Cut-Off".
- (4) When engine stops, turn ignition switch off.

**SECTION 3 GO-480, IGO-480, GSO-480, IGSO-480 SERIES**

CURVE No. 10127A

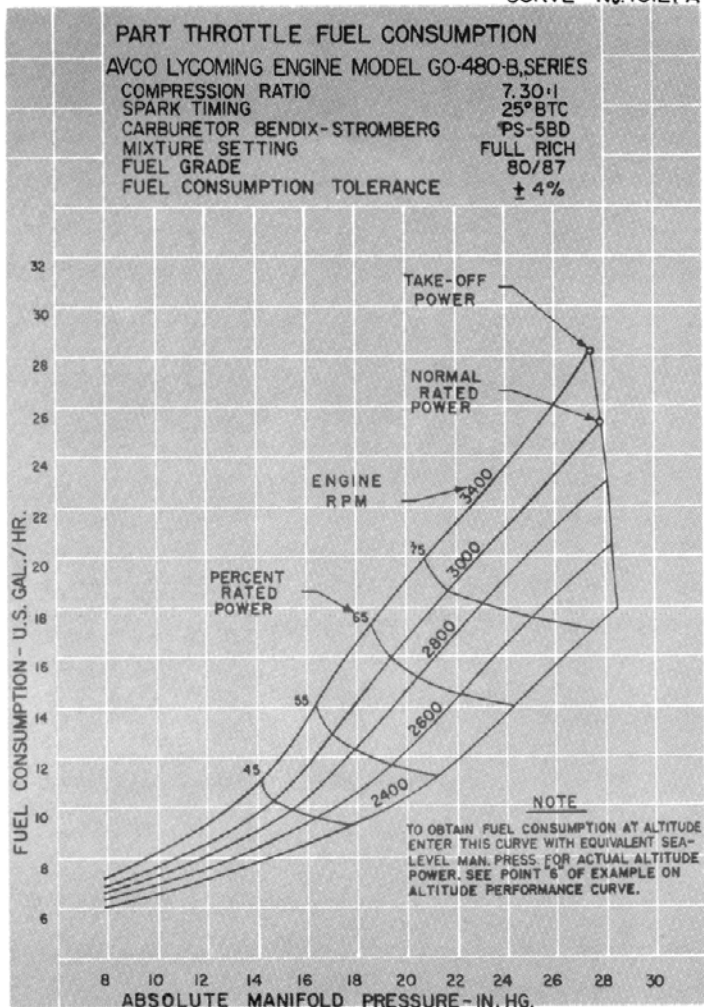

**Figure 3-2. Part Throttle Fuel Consumption Curve - GO-480-B Series**

# LYCOMING OPERATOR'S MANUAL

## GO-480, IGO-480, GSO-480, IGSO-480 SERIES SECTION 3

CURVE NO. 10126A

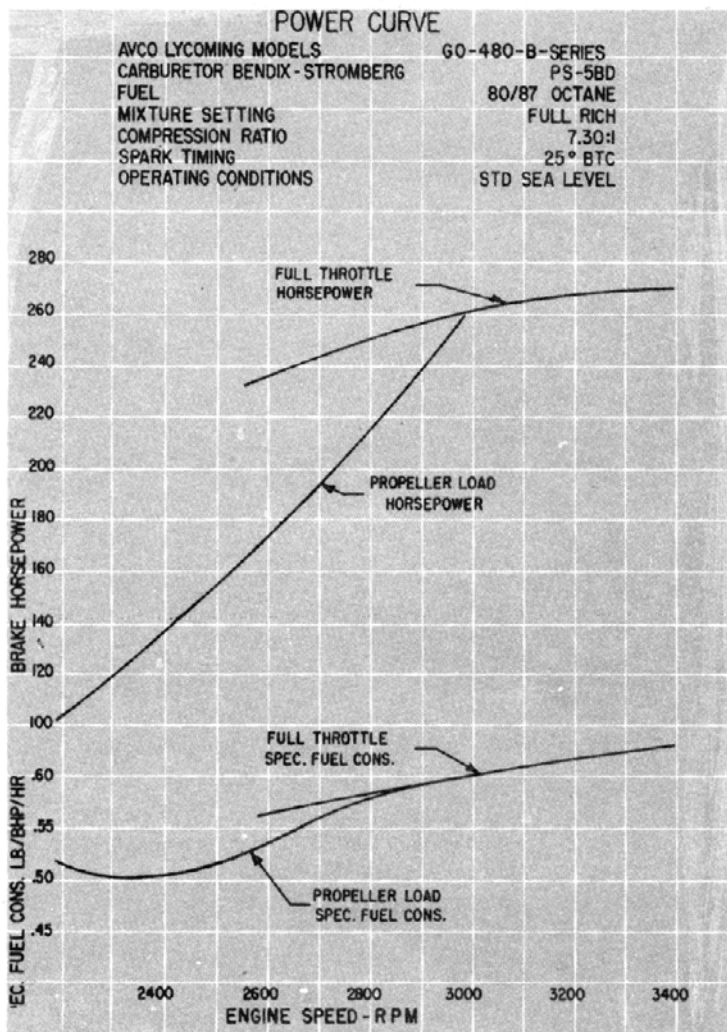

Figure 3-3. Sea Level Power Curve - GO-480-B Series

# LYCOMING OPERATOR'S MANUAL

## SECTION 3 GO-480, IGO-480, GSO-480, IGSO-480 SERIES

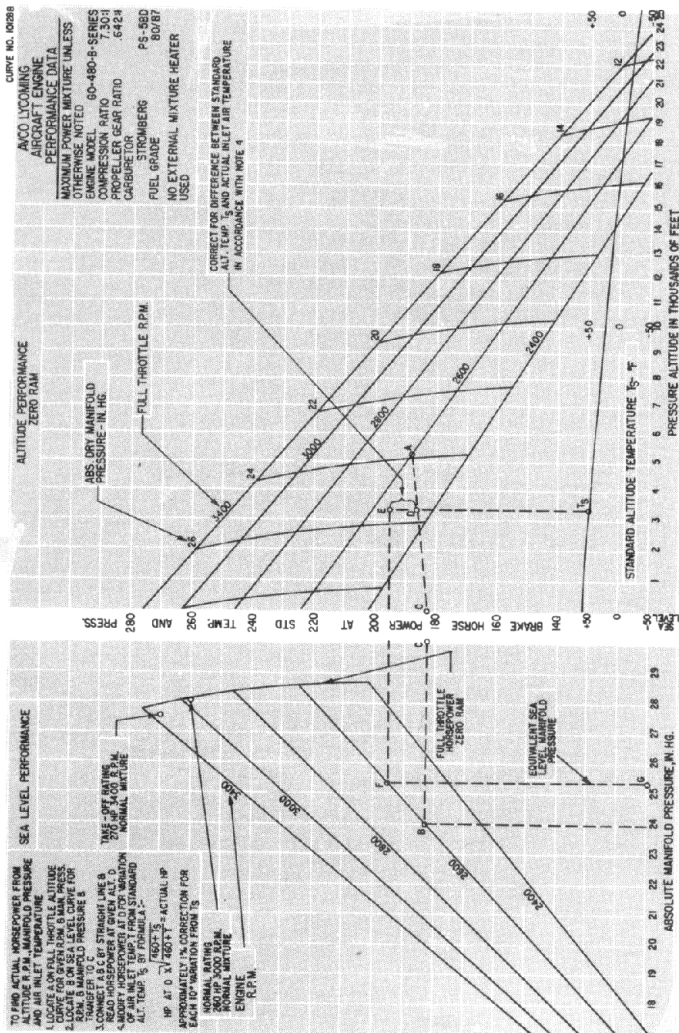

Figure 3-4. Sea Level and Altitude Performance Curve - GO-480-B Series

# LYCOMING OPERATOR'S MANUAL

## GO-480, IGO-480, GSO-480, IGSO-480 SERIES SECTION 3

CURVE NO. 10161A

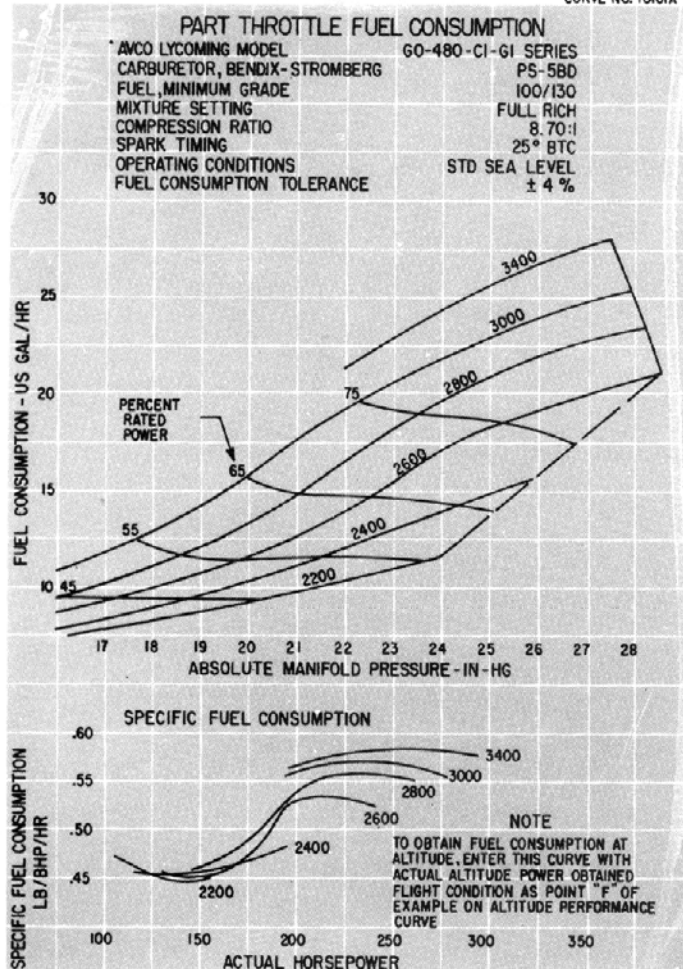

Figure 3-5. Part Throttle Fuel Consumption Curve - GO-480-C1, -G1 Series

# LYCOMING OPERATOR'S MANUAL

## SECTION 3 GO-480, IGO-480, GSO-480, IGSO-480 SERIES

CURVE No. 10160-C

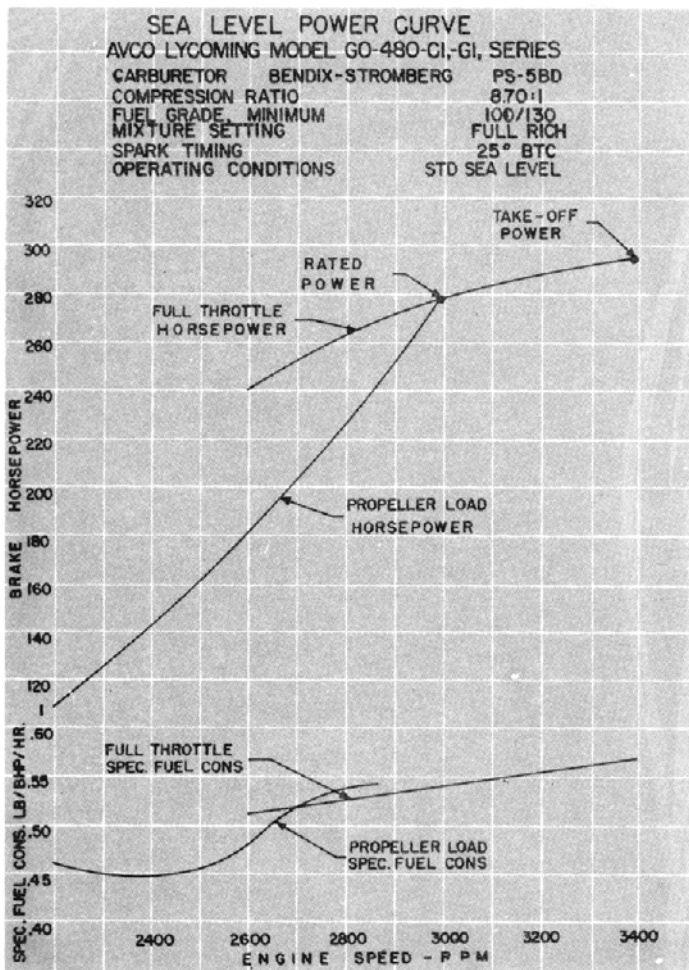

Figure 3-6. Sea Level Power Curve -  
GO-480-C1, -G1 Series

# LYCOMING OPERATOR'S MANUAL

## GO-480, IGO-480, GSO-480, IGSO-480 SERIES SECTION 3

### USING PERFORMANCE CURVE TO FIND HORSEPOWER -

The following is an example of how to use the Sea Level and Altitude performance curves for normally aspirated engines, printed on these pages, to determine actual horsepower being delivered by the engine for given altitude, RPM, manifold pressure and air inlet temperature. This example (using figure 3-7, page 3-20) is for illustration purposes only.

1. Locate the RPM and manifold pressure on the full throttle altitude curve. (Point A.)
2. Locate the same point on the sea level curve. (Point B.)
3. Transfer the value obtained in Step 2 to the horsepower scale on the altitude curve. (Point C.)
4. Draw a straight line from point "C" to point "A".
5. Read horsepower on line "CA" at flight altitude. At 3200 feet - Point "D" - 205 H. P.
6. Read inlet air temperature and correct power approximately 1% for each 10°F. variation from standard altitude temperature. Add correction for temperatures below standard; subtract for temperatures above standard. In this example the inlet air temperature is 8°F. and the standard temperature at this altitude is 48°F. This 40° variation from standard temperature represents a 4% correction, 4% of 205 H. P. is approximately 8 H. P. Since the inlet temperature is colder than standard, add 205 + 8 = 213 H. P. Points "E" and "F" on altitude chart.

Pressure Altitude (Thousands)	SL	3	6	9	12	15	18	21	24
Standard Altitude Temperature (°F.)	59	48	38	28	16	6	-5	-15	-27



# LYCOMING OPERATOR'S MANUAL

## SECTION 3 GO-480, IGO-480, GSO-480, IGSO-480 SERIES

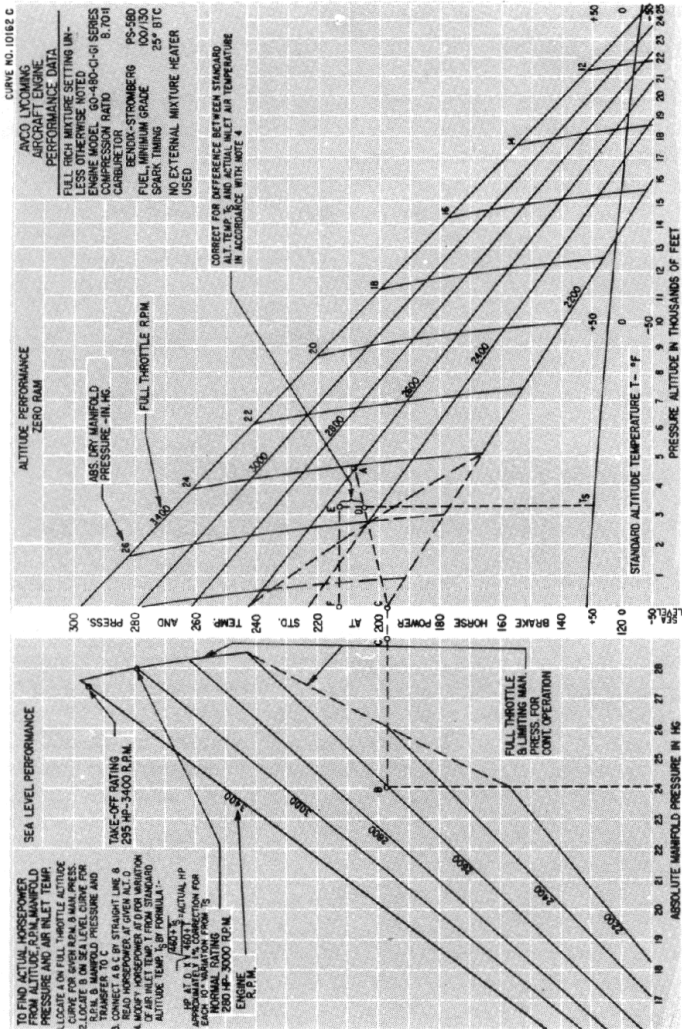

Figure 3-7. Sea Level and Altitude Performance Curve - GO-480-C1, -G1 Series

# LYCOMING OPERATOR'S MANUAL

## GO-480, IGO-480, GSO-480, IGSO-480 SERIES SECTION 3

CURVE No. 10651

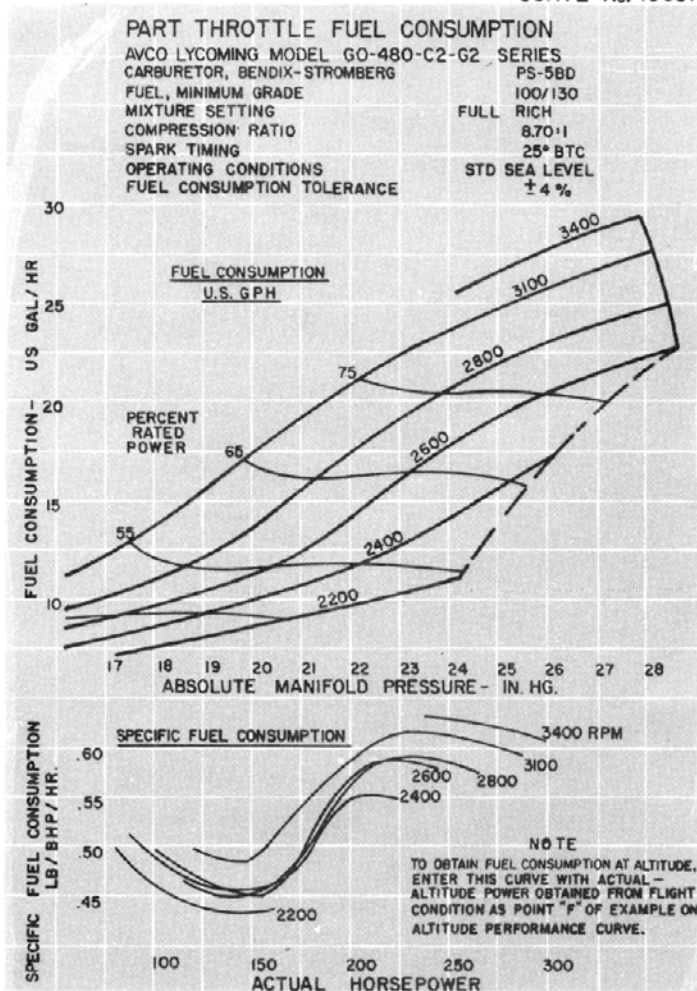

Figure 3-8. Part Throttle Fuel Consumption Curve - GO-480-C2, -G2 Series

# LYCOMING OPERATOR'S MANUAL

## SECTION 3 GO-480, IGO-480, GSO-480, IGSO-480 SERIES

CURVE NO. 10650A

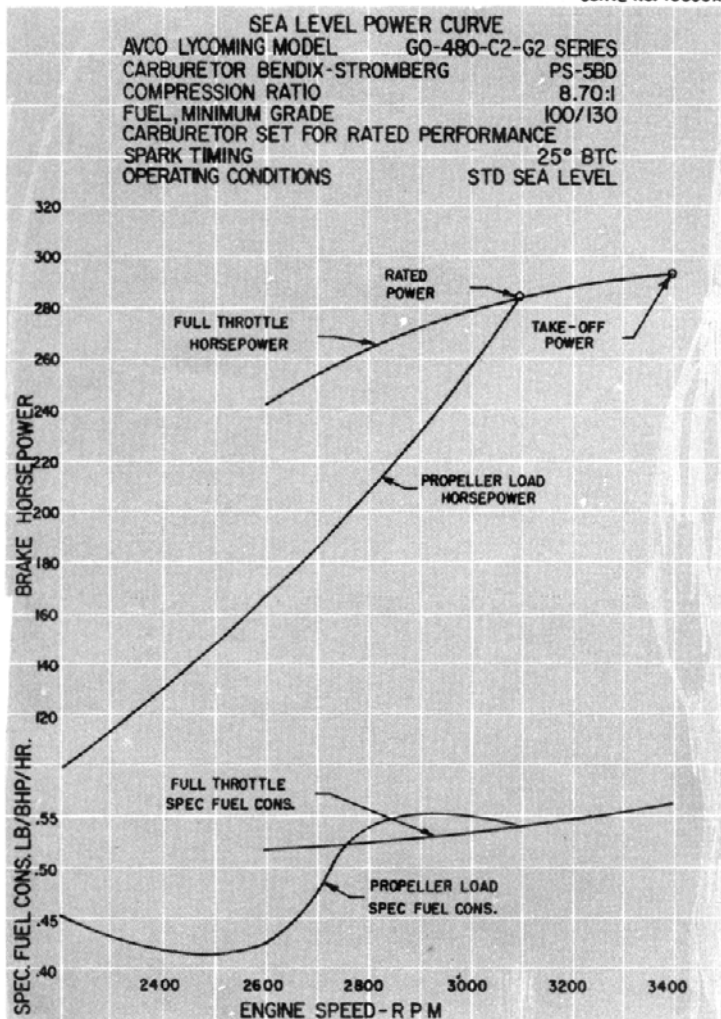

Figure 3-9. Sea Level Power Curve - GO-480-C2, -G2 Series

# LYCOMING OPERATOR'S MANUAL

## GO-480, IGO-480, GSO-480, IGSO-480 SERIES SECTION 3

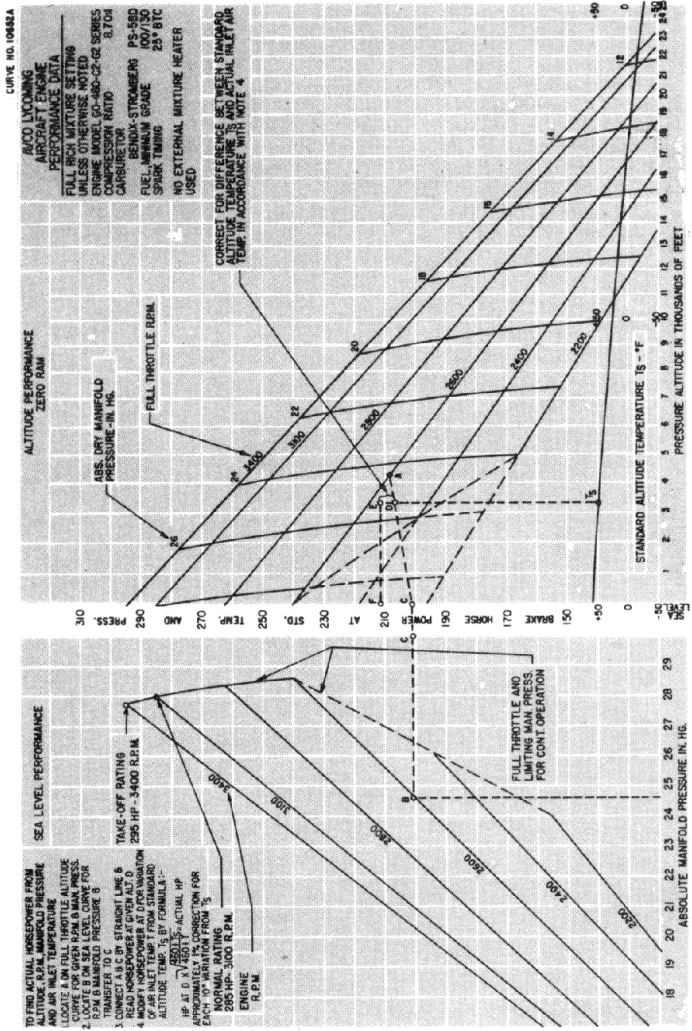

Figure 3-10. Sea Level and Altitude Performance Curve - GO-480-C2, -G2 Series

# LYCOMING OPERATOR'S MANUAL

## SECTION 3 GO-480, IGO-480, GSO-480, IGSO-480 SERIES

CURVE NO. 10845

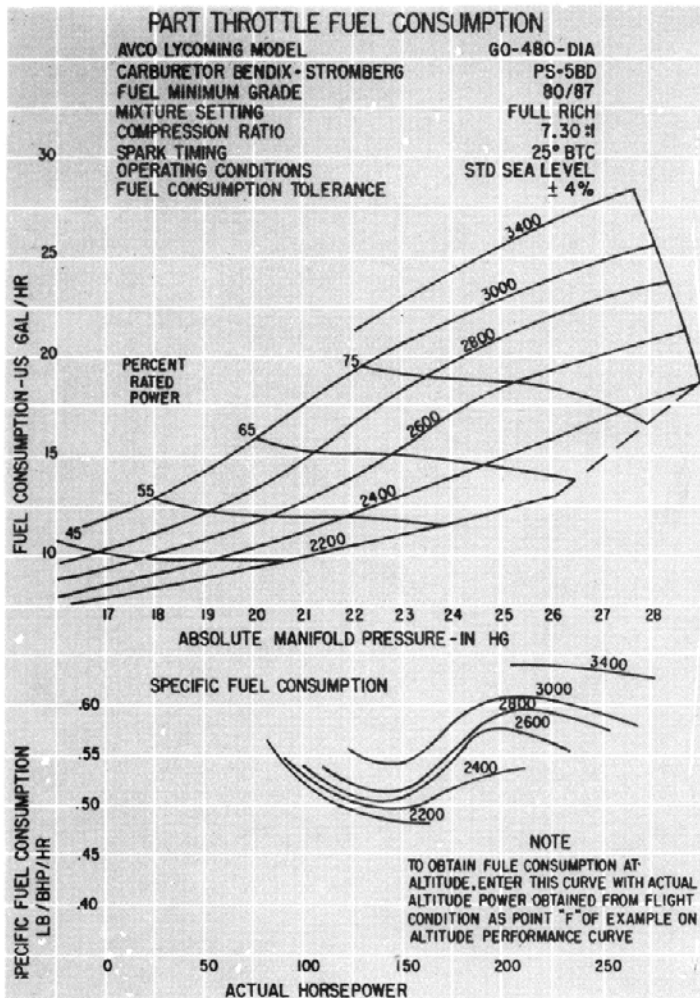

Figure 3-11. Part Throttle Fuel Consumption Curve - GO-480-D Series

# LYCOMING OPERATOR'S MANUAL

## GO-480, IGO-480, GSO-480, IGSO-480 SERIES SECTION 3

CURVE NO. 10844

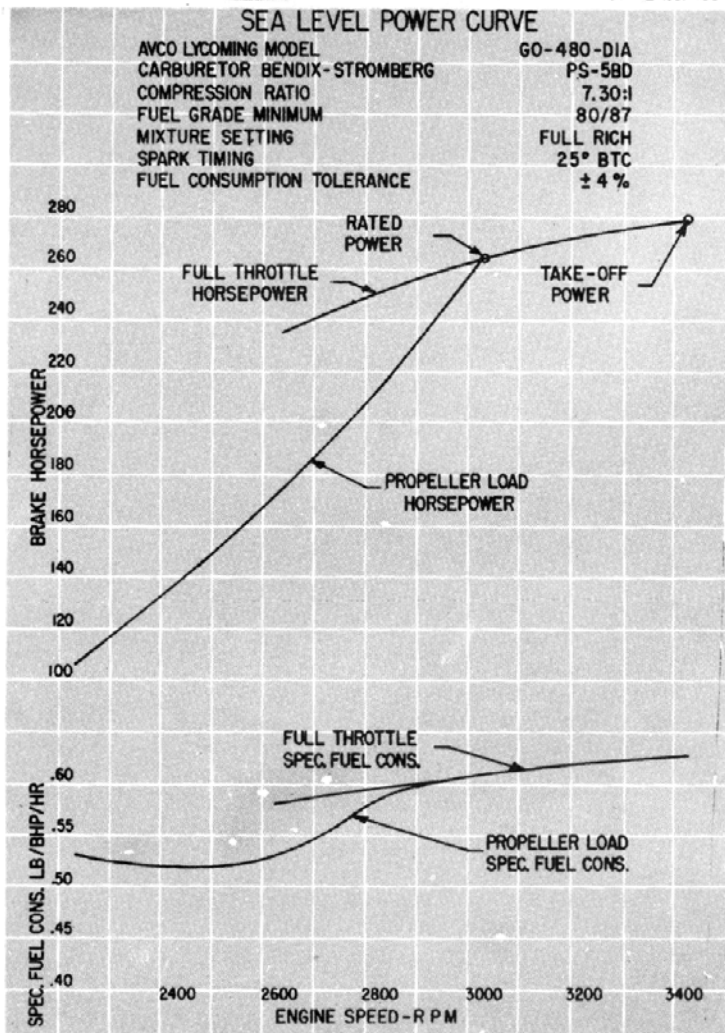

Figure 3-12. Sea Level Power Curve - GO-480-D Series

# LYCOMING OPERATOR'S MANUAL

## SECTION 3 GO-480, IGO-480, GSO-480, IGSO-480 SERIES

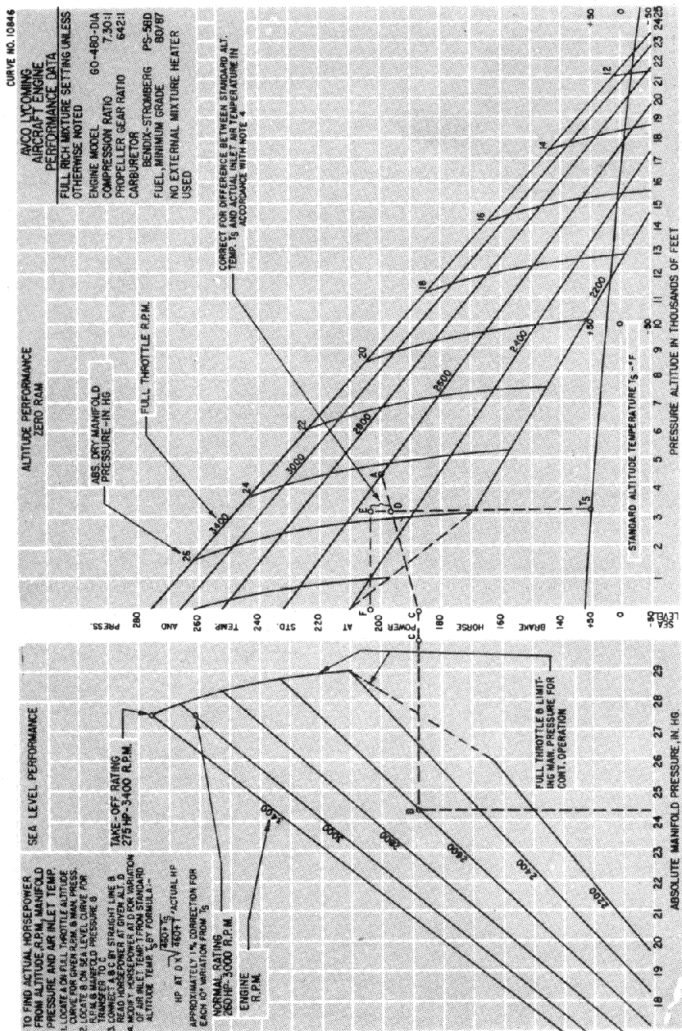

Figure 3-13. Sea Level and Altitude Performance Curve - GO-480-D Series

# LYCOMING OPERATOR'S MANUAL

GO-480, IGO-480, GSO-480, IGSO-480 SERIES SECTION 3

CURVE No. 10297A

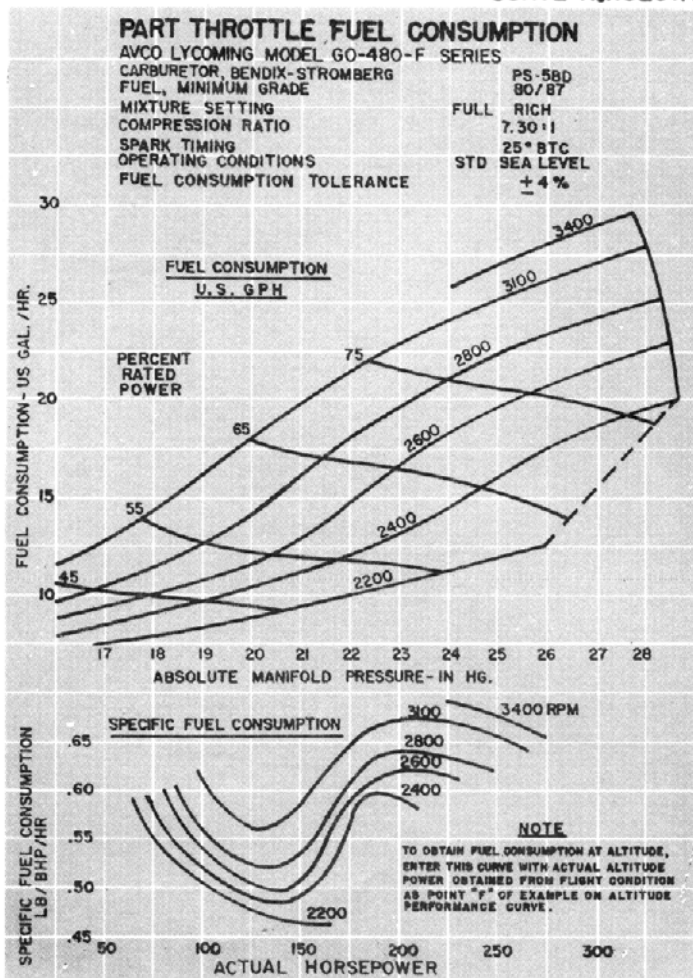

Figure 3-14. Part Throttle Fuel Consumption - GO-480-F Series



# LYCOMING OPERATOR'S MANUAL

## SECTION 3 GO-480, IGO-480, GSO-480, IGO-480 SERIES

CURVE No. 10296 B

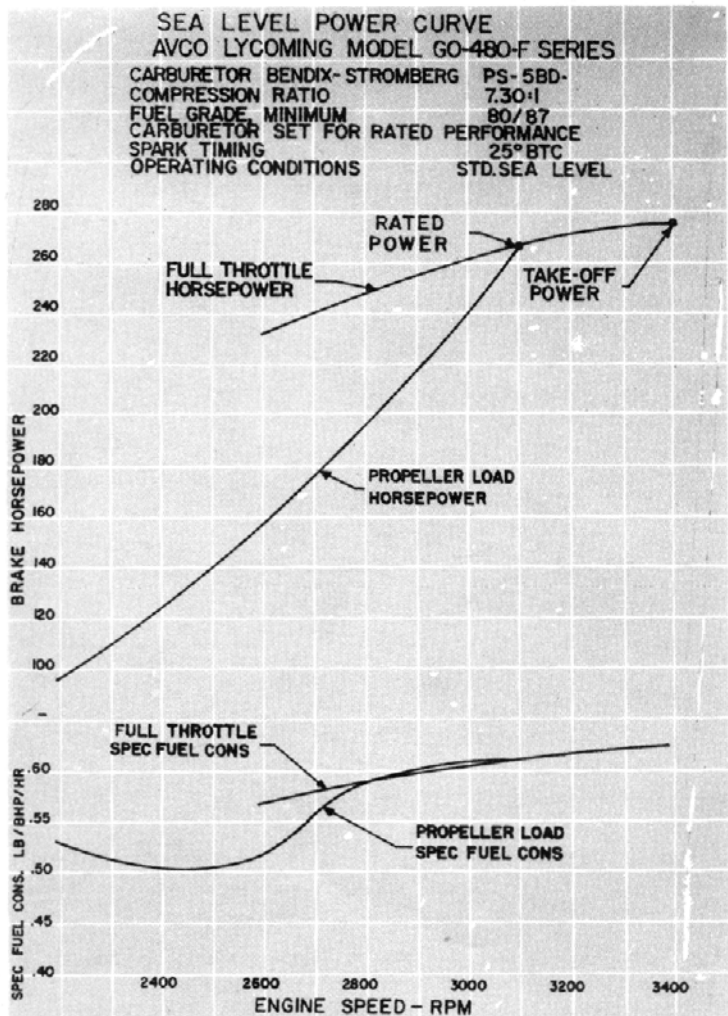

Figure 3-15. Sea Level Power Curve - GO-480-F Series

# LYCOMING OPERATOR'S MANUAL

## GO-480, IGO-480, GSO-480, IGSO-480 SERIES SECTION 3

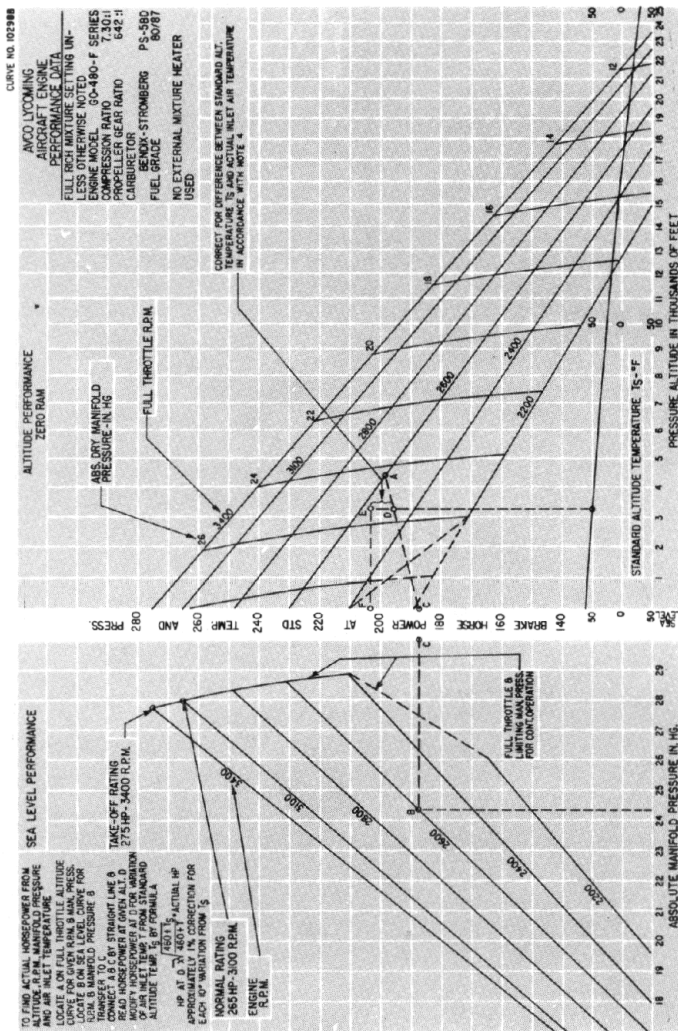

Figure 3-16. Sea Level and Altitude Performance Curve - GO-480-F Series

# LYCOMING OPERATOR'S MANUAL

## SECTION 3 GO-480, IGO-480, GSO-480, IGSO-480 SERIES

CURVE NO. 1008581

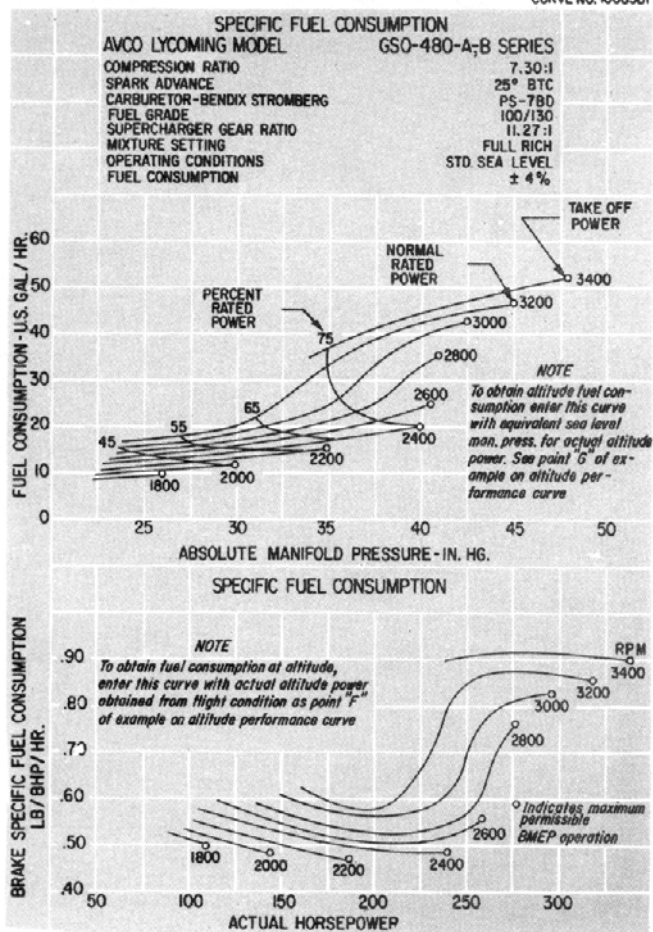

Figure 3-17. Specific Fuel Consumption - GSO-480-A, -B Series

# LYCOMING OPERATOR'S MANUAL

## GO-480, IGO-480, GSO-480, IGSO-480 SERIES SECTION 3

CURVE No. 10811A

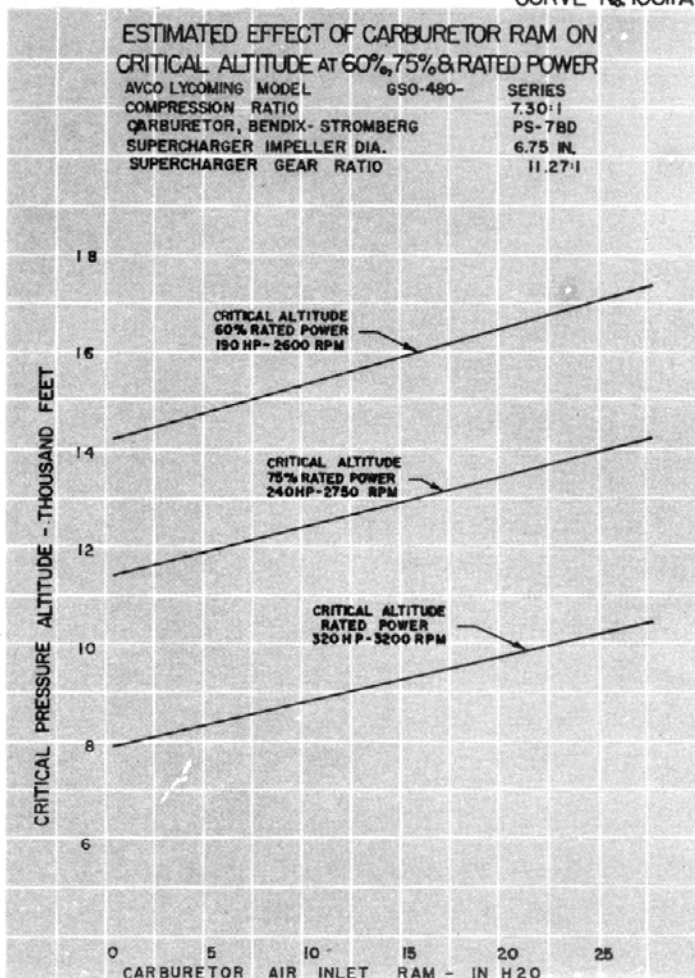

Figure 3-18. Estimated Effect of Carburetor Ram on Critical Altitude - GSO-480 Series

# LYCOMING OPERATOR'S MANUAL

## SECTION 3 GO-480, IGO-480, GSO-480, IGSO-480 SERIES

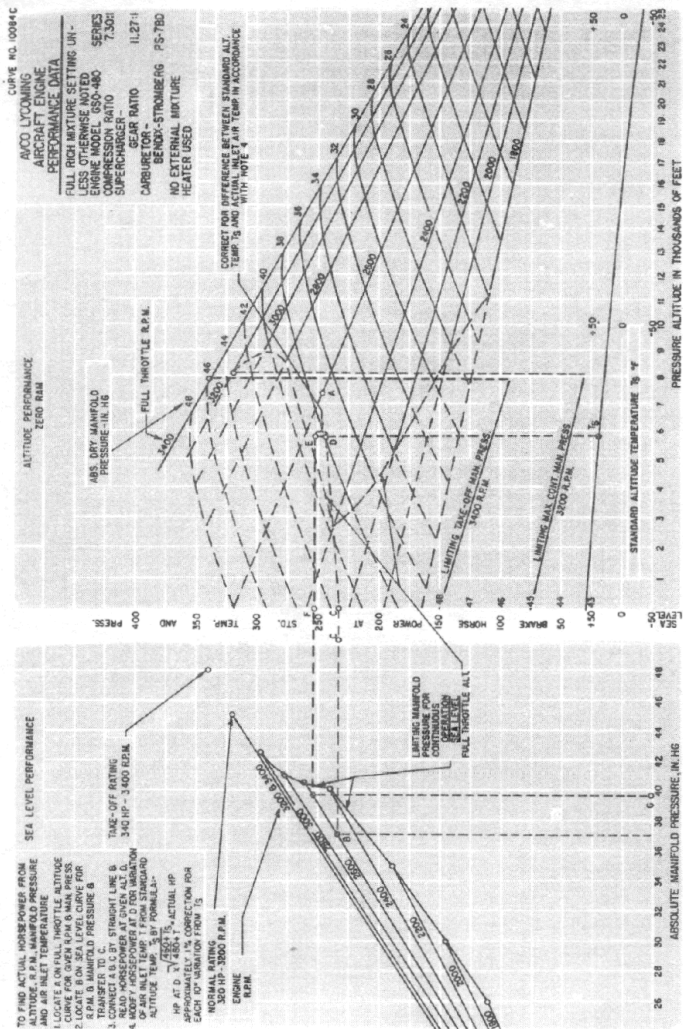

Figure 3-19. Sea Level and Altitude Performance Curve - GSO-480 Series

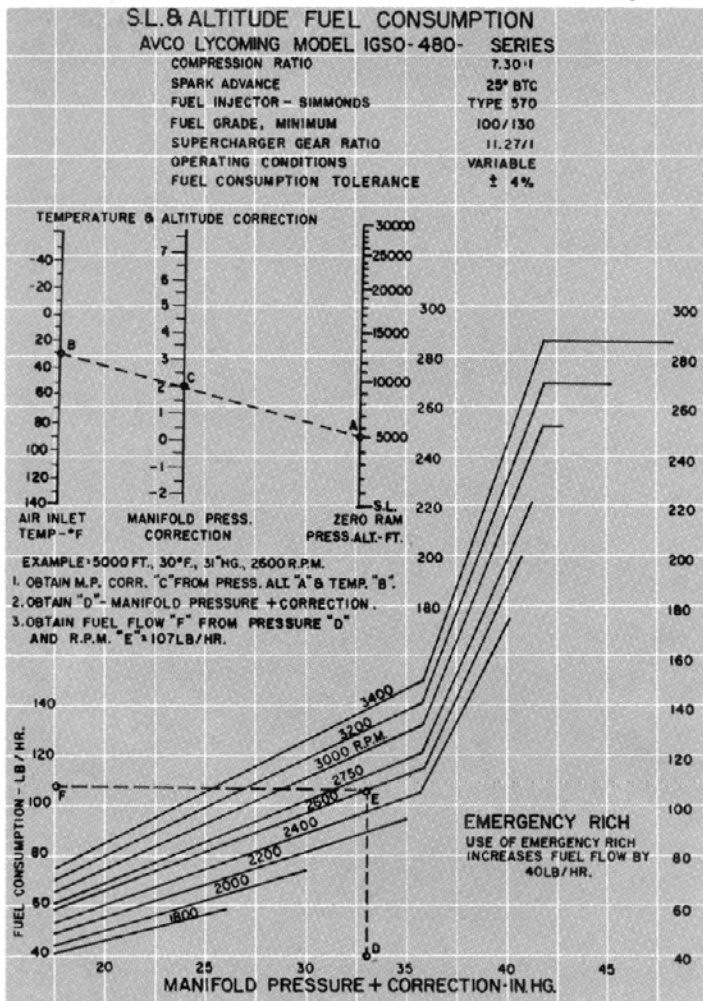

Figure 3-20. Sea Level and Altitude Fuel Consumption - IGSO-480-A1A6, -A1B6, -A1C6, -A1F3, -A1F6

## SECTION 3

## GO-480, IGO-480, GSO-480, IGSO-480 SERIES

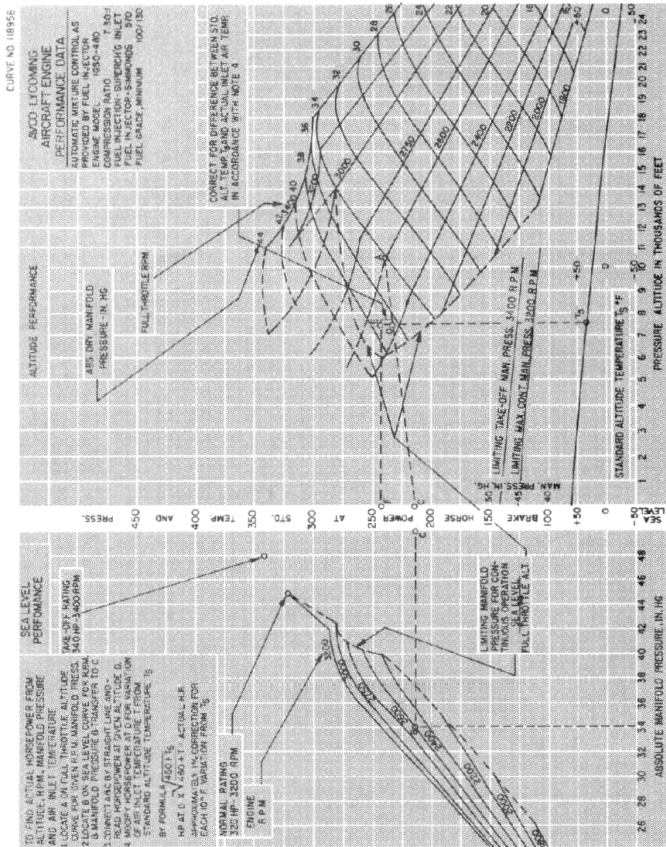

Figure 3-21. Sea Level and Altitude Performance Curve - IGSO-480-A1A6, -A1B6, -A1C6, -A1F3, -A1F6

# LYCOMING OPERATOR'S MANUAL

## GO-480, IGO-480, GSO-480, IGSO-480 SERIES SECTION 3

CURVE NO.12916

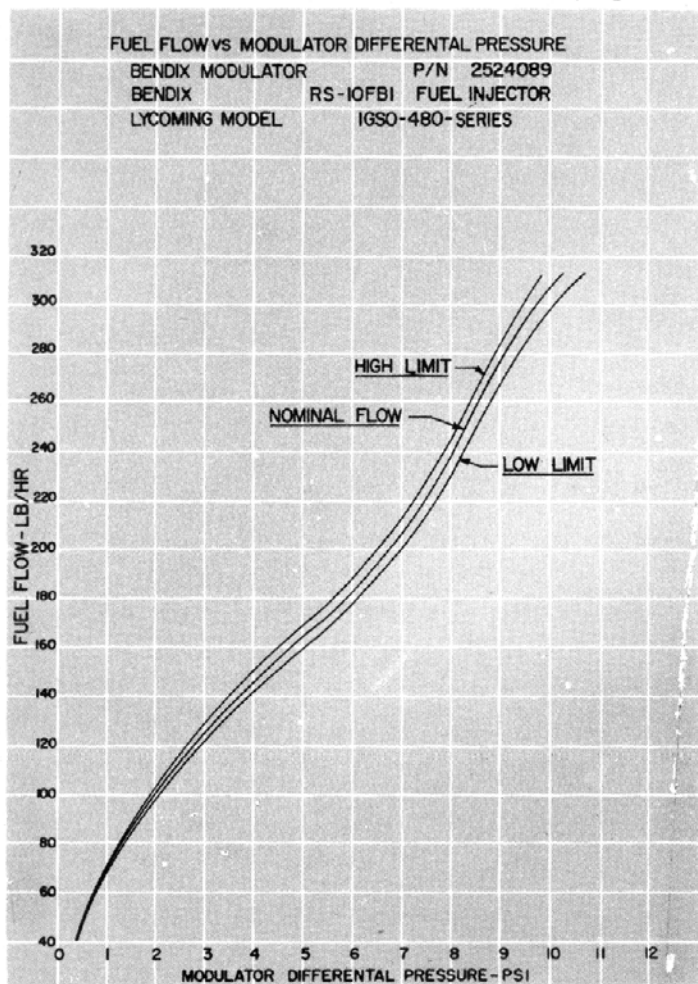

Figure 3-22. Fuel Flow vs Modulator Differential Pressure - IGSO-480-A1D6, -A1E6, -A1G6



# LYCOMING OPERATOR'S MANUAL

## SECTION 3 GO-480, IGO-480, GSO-480, IGSO-480 SERIE

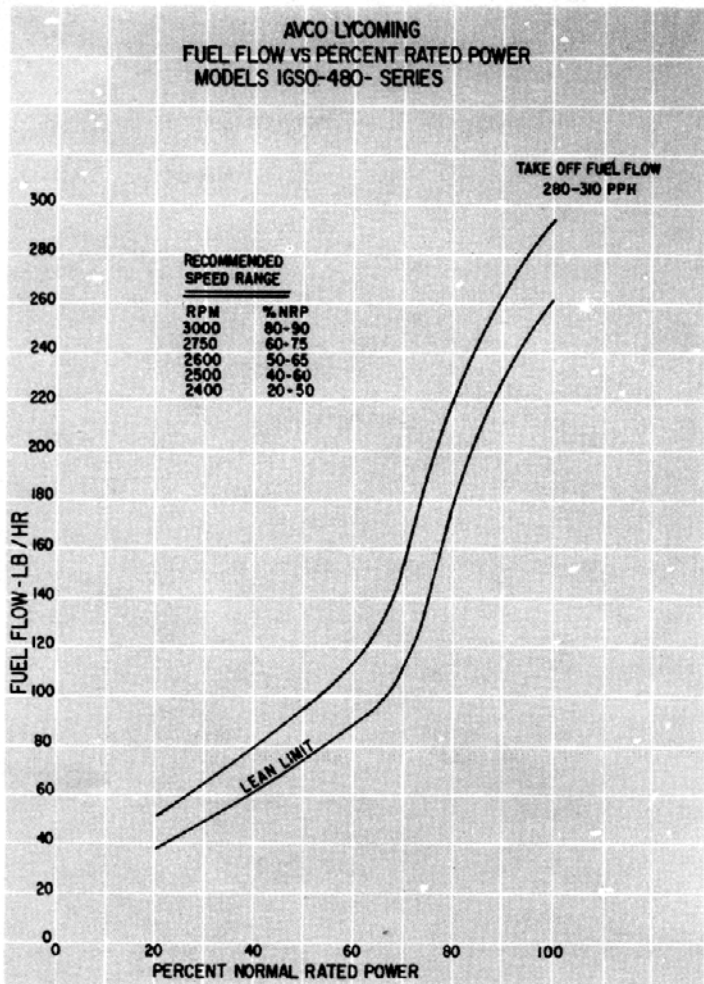
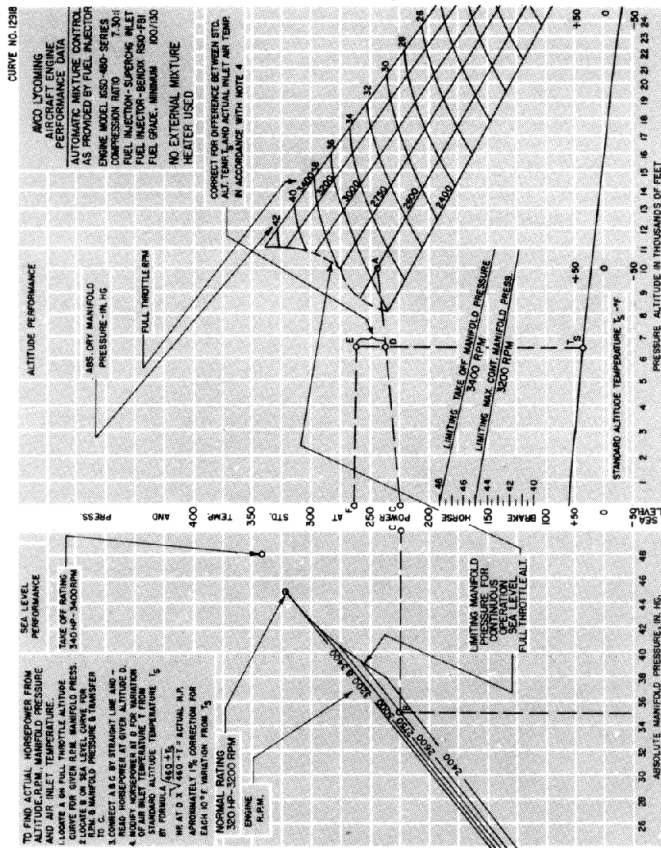

Figure 3-23. Fuel Flow vs Percent of Rated Power -  
IGSO-480-A1D6, -A1E6, -A1G6

# LYCOMING OPERATOR'S MANUAL

## GO-480, IGO-480, GSO-480, IGSO-480 SERIES SECTION 3



# LYCOMING OPERATOR'S MANUAL

## SECTION 3 GO-480, IGO-480, GSO-480, IGSO-480 SERIES

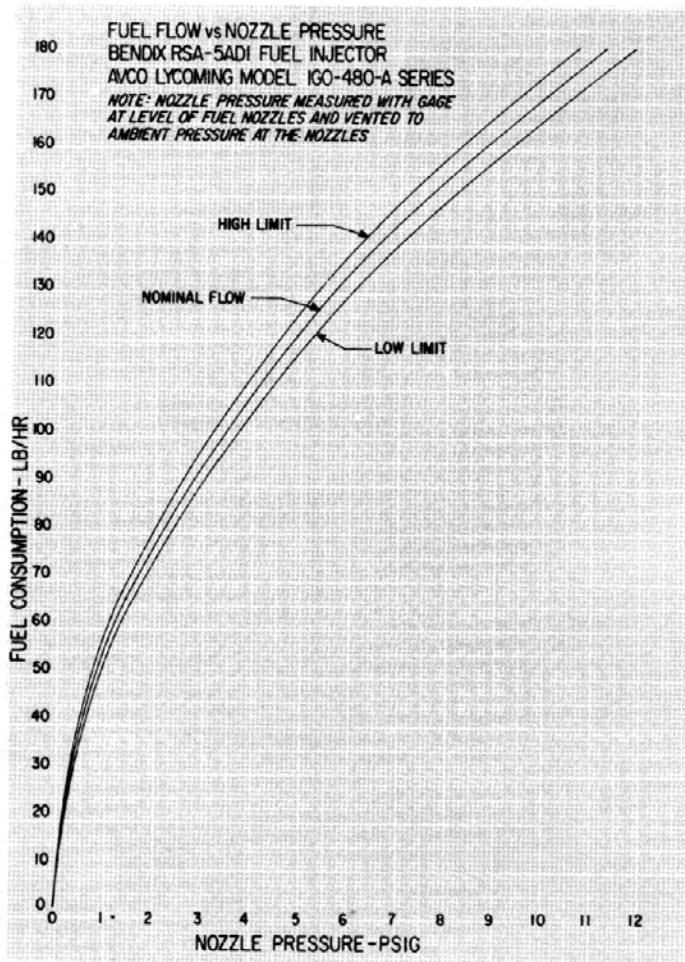

Figure 3-25. Fuel Flow vs Nozzle Pressure - IGO-480-A Series

# LYCOMING OPERATOR'S MANUAL

## GO-480; IGO-480, GSO-480, IGSO-480 SERIES SECTION 3

CURVE No. 13128

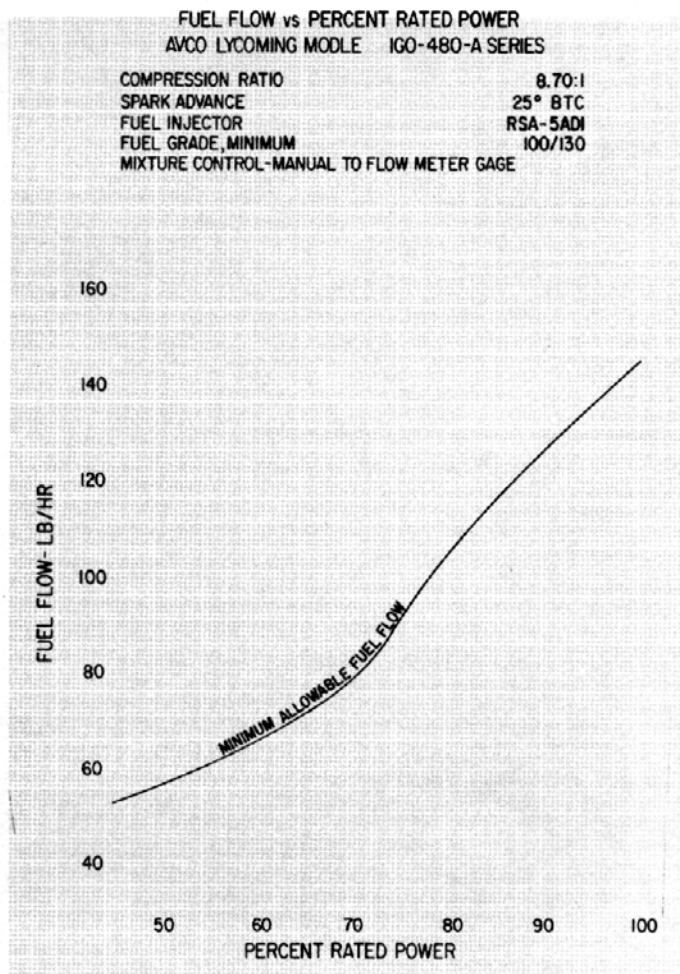
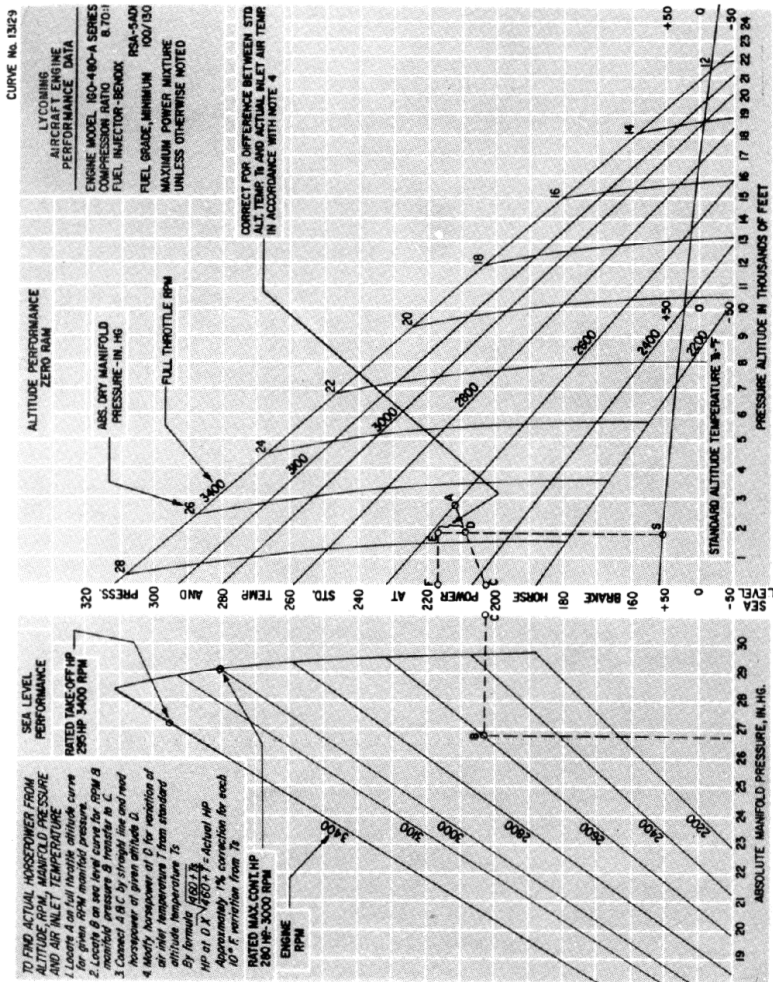

Figure 3-26. Fuel Flow vs Percent Rated Power - IGO-480-A Series

# LYCOMING OPERATOR'S MANUAL

## SECTION 3 GO-480, IGO-480, GSO-480, IGSO-480 SERIES



# LYCOMING OPERATOR'S MANUAL

## PERIODIC INSPECTIONS

	Page
Pre-Starting Inspection . . . . .	4-1
Daily Pre-Flight . . . . .	4-2
25 Hour Inspection . . . . .	4-2
50 Hour Inspection . . . . .	4-2
100 Hour Inspection . . . . .	4-4
400 Hour Inspection . . . . .	4-5
Valve Inspection . . . . .	4-5

# LYCOMING OPERATOR'S MANUAL

GO-480, IGO-480, GSO-480, IGSO-480 SERIES SECTION 4

## SECTION 4

### PERIODIC INSPECTIONS

#### NOTE

*Perhaps no other factor is quite so important to safety and durability of the aircraft and its components as faithful and diligent attention to regular checks for minor troubles and prompt repair when they are found.*

The operator should bear in mind that the items listed in the following pages do not constitute a complete aircraft inspection, but are meant for the engine only. Consult the airframe manufacturer's handbook for additional instructions.

*Pre-Starting Inspection* - The daily pre-flight inspection is a check of the aircraft prior to the first flight of the day. This inspection is to determine the general condition of the aircraft and engine.

The importance of proper pre-flight inspection cannot be over emphasized. Statistics prove several hundred accidents occur yearly directly reponsible to poor pre-flight.

Among the major causes of poor pre-flight inspection are the lack of concentration, reluctance to acknowledge the need for a check list, carelessness bred by familiarity and haste.

# LYCOMING OPERATOR'S MANUAL

## SECTION 4 GO-480, IGO-480, GSO-480, IGSO-480 SERIES

### 1. DAILY PRE-FLIGHT.

- a. Be sure all switches are in "Off" position.
- b. Be sure magneto ground wires are connected.
- c. See that fuel tanks are full.
- d. Check oil level.
- e. Check fuel and oil line connections. Note minor indications for repair at 50 hour inspection. Repair any leaks before aircraft is flown.
- f. Open fuel drain to remove any accumulation of water and sediment.
- g. Make sure all shields and cowling are in place and secure. If any are missing or damaged, repair or replacement must be made before the aircraft is flown.
- h. Check controls for general condition, travel and freedom of operation.
- i. Induction system air filter should be inspected and serviced in accordance with airframe manufacturer's recommendations.

2. **25 HOUR INSPECTION.** After the first twenty-five hours operating time new, remanufactured, or newly overhauled engines should undergo a 50 hour inspection including draining and renewing lubrication oil.

3. **50 HOUR INSPECTION.** In addition to the items listed for daily pre-flight inspection, the following maintenance checks should be made after every 50 hours of operation.

#### *a. Ignition System -*

- (1) If fouling of spark plugs has been apparent, rotate bottom plugs to top position.



(2) Examine spark plug leads and ceramics for corrosion and deposits. This condition is evidence of either leaking spark plugs or improper cleaning of the spark plug walls and connector ends. Where this condition is found, clean the cable ends, spark plug walls and ceramics with a dry, clean cloth or a cloth moistened with methyl-ethyl ketone. All parts should be clean and dry before reassembly.

(3) Check ignition harness for security of mounting clamps, and be sure connections are tight at spark plug and magneto terminals.

*b. Fuel and Induction System* - Check the primer lines for leaks and security of clamps. Remove and clean the fuel inlet strainers. Check the mixture control and throttle linkage for travel, freedom of movement, security of the clamps and lubricate if necessary. Check the air intake ducts for leaks, security or filter damage. Evidence of dust or other solid material in the ducts is indicative of inadequate filter care or damaged filter. Check vent lines for evidence of fuel or oil seepage. If present, fuel pump may require replacement.

*c. Lubrication System* -

(1) Check oil lines for leaks, particularly at connections. Check for security of anchorage, wear due to rubbing or vibration, dents and cracks.

(2) *Engines with Side Mounted Accessories* - Remove oil pump filter and clean thoroughly as described in Section 5, 3-b of this manual. Note carefully of presence of metal particles that are indicative of internal engine damage.

(3) Drain and renew lubricating oil.

*d. Exhaust System* - Check attaching flanges at exhaust ports on cylinders for evidence of leakage. If they are loose, they must be removed and machined flat before they are reassembled and tightened. Examine exhaust manifolds for general condition.

**SECTION 4 GO-480, IGO-480, GSO-480, IGSO-480 SERIES**

*e. Cooling System* - Check cowling and baffles for damage and secure anchorage. Any damaged or missing part of the cooling system must be repaired or replaced before the aircraft resumes operation.

*f. Cylinders* - Check rocker box covers for evidence of oil leaks. If found, replace gasket and tighten screws to specified torque.

Check cylinders for evidence of excessive heat which is indicated by burned paint on the cylinder. This condition is indicative of internal damage to the cylinder. If found, its cause must be determined and corrected before the aircraft resumes operation.

Heavy discoloration and appearance of seepage at cylinder head and barrel attachment area is usually due to emission of thread lubricant used during assembly of the barrel at the factory, or by slight gas leakage which stops after the cylinder has been in service for awhile. This condition is neither harmful nor detrimental to engine performance and operation. If it can be proven that leakage exceeds these conditions, the cylinder should be replaced.

**5. 100 HOUR INSPECTION.** In addition to the items listed for daily pre-flight and 50 hour inspection, the following maintenance checks should be made after every one hundred hours of operation.

*a. Electrical System* -

(1) Check all wiring connected to the engine or accessories. Any shielded cables that are damaged should be replaced. Replace clamps or loose wires and check terminals for security and cleanliness.

(2) Remove spark plugs; test clean and regap. Replace if necessary.

*b. Magnets* - Check breaker points for pitting and minimum gap. Check for excessive oil in breaker compartment. If found, wipe dry with a clean, lintless cloth. The felt located at the breaker points should be lubricated in accordance with the magneto manufacturer's instructions. Check magneto to engine timing. Timing procedure is described in Section 5, 1-b (1) of this manual.

# LYCOMING OPERATOR'S MANUAL

## GO-480, IGO-480, GSO-480, IGSO-480 SERIES SECTION 4

*c. Engine Accessories* - Engine mounted accessories such as pumps and temperature or pressure sensing units should be checked for secure mounting and tight connections.

*d. Cylinders* - Check cylinders visually for cracked or broken fins.

*e. Engine Mounts* - Check engine mounting bolts for security and excessive wear. Replace any excessively worn bushings.

**6. 400 HOUR INSPECTION.** In addition to the items listed for daily pre-flight, 50 hour and 100 hour inspections, the following maintenance check should be made every 400 hours of operation.

*Valve Inspection* - Remove rocker box covers and check for freedom of valve rockers when valves are closed. Look for evidence of abnormal wear or broken parts in the area of valve tips, valve keepers, springs and spring seats. If any indications are found, the cylinder and all of its components (including the piston and connecting rod assembly) should be removed and inspected for further damage. Replace any parts that do not conform to limits shown in the latest revision of Special Service Publication No. SSP2070.

# LYCOMING OPERATOR'S MANUAL

## MAINTENANCE PROCEDURES

Page

### Ignition and Electrical System

Ignition Harness and Wire Replacement . . . . .	5-1
Timing Magneto to Engine . . . . .	5-1
Generator or Alternator Output . . . . .	5-4

### Fuel System

Repair of Fuel Leaks . . . . .	5-4
Carburetor or Fuel Injector Inlet	
Screen Assembly . . . . .	5-4
Fuel Grades and Limitations . . . . .	5-4
Air Intake Ducts and Filter . . . . .	5-4
Idle Speed and Mixture Adjustment . . . . .	5-5

### Lubrication System

Oil Grades and Limitations . . . . .	5-6
Oil Filter . . . . .	5-6
Oil Relief Valve . . . . .	5-6

Cylinders . . . . .	5-6
---------------------	-----

# LYCOMING OPERATOR'S MANUAL

GO-480, IGO-480, GSO-480, IGSO-480 SERIES SECTION 5

## SECTION 5

### MAINTENANCE PROCEDURES

The procedures described in this section are provided to guide and instruct personnel in performing maintenance operations that may be required in conjunction with the periodic inspections listed in the preceding section. No attempt is made to include repair and replacement operations that will be found in the applicable Avco Lycoming Overhaul Manual.

#### *1. IGNITION AND ELECTRICAL SYSTEM.*

*a. Ignition Harness and Wire Replacement* - In the event that an ignition harness or an individual lead is to be replaced, consult the wiring diagram to be sure harness is correctly installed. Mark location of clamps and clips to be certain the replacement is clamped at correct locations.

*b. Timing Magnets to Engine* - Although several combinations of magnets are used on this series engines, (see Table of Models for model application) the timing procedures, in the following paragraphs, are the same for all magnets.

#### *NOTE*

*Either the impulse coupling or retard breaker magneto (whichever is applicable) is installed in the left side of the engine.*

(1) Remove a spark plug from the No. 1 cylinder (the front cylinder on the right). Also remove the inspection plug from the top of the reduction gear (rear mounted accessories) or from the right side of the accessory housing (crosswise accessories). Turn the crankshaft in direction of normal rotation until pressure can be felt when the thumb is pressed against the spark plug hole. Continue turning the crankshaft until the timing pointer is in alignment with the mark in the gear, which can be observed through the inspection hole. At this point, the engine is at 25° BTC on the compression stroke of No. 1 cylinder and is ready for assembly of the magnets.

# LYCOMING OPERATOR'S MANUAL

## SECTION 5 GO-480, IGO-480, GSO-480, IGSO-480 SERIES

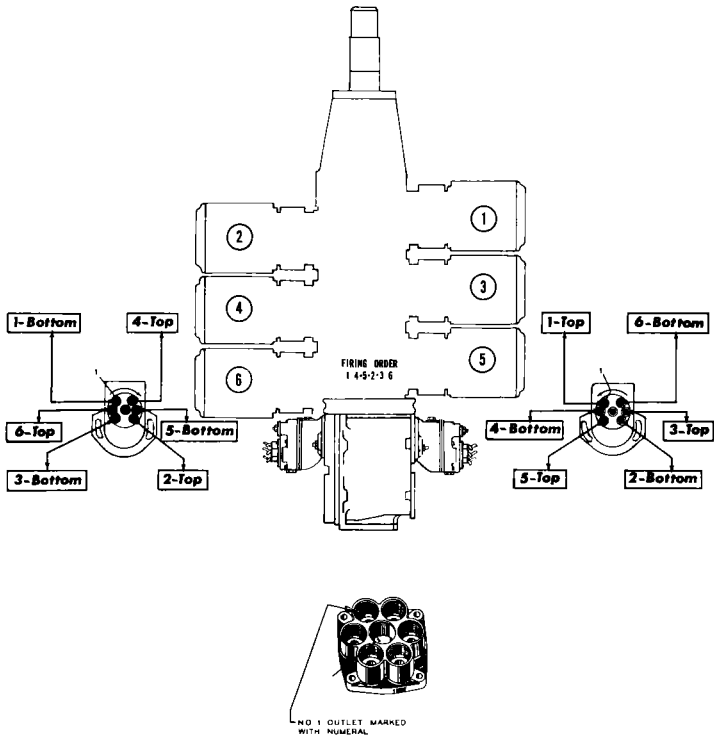

Figure 5-1. Ignition Wiring Diagram

## LYCOMING OPERATOR'S MANUAL

### GO-480, IGO-480, GSO-480, IGSO-480 SERIES SECTION 5

(2) At this point, the engine is ready for assembly of the magnetos. Remove the inspection plugs from both magnetos and turn the drive shafts in direction of normal rotation until the first painted chamfered tooth on the distributor gear is aligned in the center of the inspection window. Being sure that the gear does not move from this position, install gaskets and magnetos on the engine. Secure with washers and nuts; tighten only finger tight.

#### NOTE

*In order to turn the shaft on an impulse coupling magneto, depress the pawl on the impulse coupling with the finger.*

(3) Using a battery powered timing light, attach the positive lead to a suitable terminal connected to the ground terminal of the magneto and the negative lead to any unpainted portion of the engine. Rotate the magneto in its mounting flange to a point where the light comes on, then slowly turn it in the opposite direction until the light goes out. Bring the magneto back slowly until the light just comes on. Repeat this with the second magneto.

#### NOTE

*Some timing lights operate in the reverse manner as described. The light comes on when the breaker points open. Check your timing light instructions.*

(4) After both magnetos have been timed, check, as described below, to ascertain that both magnetos are set to fire together.

(5) Back off the crankshaft a few degrees, the timing lights should go out. Bring the crankshaft slowly back in direction of normal rotation until the timing pointer and the marked tooth on the camshaft gear are in alignment. At this point, both lights should go on simultaneously. Tighten nuts to specified torque.

# LYCOMING OPERATOR'S MANUAL

## SECTION 5 GO-480, IGO-480, GSO-480, IGSO-480 SERIES

*c. Generator or Alternator Output* - The generator or alternator (whichever is applicable) should be checked to determine that the specified voltage and current are being obtained.

### 2. FUEL SYSTEM.

*a. Repair of Fuel Lines* - In the event a line or fitting is replaced, only a fuel soluble lubricant, such as clean engine oil or Loctite Hydraulic Sealant may be used on the tapered threads. Do not use any other form of thread compound.

*b. Carburetor or Fuel Injector Inlet Screen Assembly* - Remove the assembly and check the screen for distortion or openings in the strainer. Replace for either of these conditions. Clean screen assembly in solvent and dry with compressed air. To install the screen assembly, place the gasket on the screen assembly. Install the assembly in the throttle body and tighten to recommended torque.

*c. Fuel Grades and Limitations* - For recommended fuel, see page 3-10.

In the event that the specified fuel is not available at some locations, it is permissible to use higher octane fuel. Fuel of a lower octane than specified is not to be used. Under no circumstances should automotive fuel be used (regardless of octane rating).

### NOTE

*It is recommended that personnel be familiar with Service Instruction No. 1070 regarding specified fuel for Avco Lycoming engines.*

*d. Air Intake Ducts and Filter* - Check all air intake ducts for dirt or restrictions. Inspect and service air filters as instructed in the airframe manufacturer's handbook.



## LYCOMING OPERATOR'S MANUAL

GO-480, IGO-480, GSO-480, IGSO-480 SERIES SECTION 5

### *e. Idle Speed and Mixture Adjustment -*

- (1) Start the engine and warm up in the usual manner until oil and cylinder head temperatures are normal.
- (2) Check magnetos. If the "mag-drop" is normal, proceed with idle adjustment.
- (3) Set throttle stop screw so that the engine idles at the airframe manufacturer's recommended idling RPM. If the RPM changes appreciably after making idle mixture adjustment during the succeeding steps, readjust the idle speed to the desired RPM.
- (4) When the idling speed has been stabilized, move the cockpit mixture control lever with a smooth, steady pull toward the "Idle Cut-Off" position and observe the tachometer for any change during the leaning process. Caution must be exercised to return the mixture control to the "Full Rich" position before the RPM can drop to a point where the engine cuts out. An increase of more than 50 RPM while "leaning out" indicates an excessively rich idle mixture. An immediate decrease in RPM (if not preceded by a momentary increase) indicates the idle mixture is too lean.

If the above indicates that the idle adjustment is too rich or too lean, turn the idle mixture adjustment in the direction required for correction, and check this new position by repeating the above procedure. Make additional adjustments as necessary until a check results in a momentary pick-up of approximately 50 RPM. Each time the adjustment is changed the engine should be run up to 2000 RPM to clear the engine before proceeding with the RPM check. Make final adjustment of the idle speed adjustment to obtain the desired idling RPM with closed throttle. The above method aims at a setting that will obtain maximum RPM with minimum manifold pressure. In case the setting does not remain stable, check the idle linkage; any looseness in this linkage would cause erratic idling. In all cases, allowance should be made for the effect of weather conditions and field altitude upon idling adjustment.

# LYCOMING OPERATOR'S MANUAL

## SECTION 5 GO-480, IGO-480, GSO-480, IGSO-480 SERIES

### 3. LUBRICATION SYSTEM.

*a. Oil Grades and Limitations* - Service the engine in accordance with the recommendations on page 3-10.

*b. Oil Filter* - Clean the engine oil filter as follows: Under normal conditions, washing the filter assembly with varsol and compressed air will be sufficient. If the filter is heavily carboned, it may be dipped in a decarbonizing solution (usually heated). A great many decarbonizing agents are available, including such products as Gunk, Penetrol and many others. The loosened carbon can be washed away with varsol and compressed air. The filter may also be cleaned by boiling in water and a commercial detergent for a period of ten minutes, rinsed and dried with compressed air.

*c. Oil Relief Valve* - These engines are furnished with an adjustable oil pressure relief valve which enables the operator to maintain engine oil pressure within the specified limits (65-85 psi.). If the pressure under normal operation conditions should consistently exceed 85 psi. or run less than 65 psi., adjust the valve as follows:

With the engine thoroughly warmed up and running at a maximum of 2200 RPM, observe the oil pressure gage reading. If the oil pressure is above 85 psi. or below 65 psi., stop the engine, remove the crown nut, locknut and both copper asbestos gaskets. Install new gaskets with the unbroken surface of each gasket outward. Then turn the adjusting screw inward (clockwise) to increase oil pressure or outward (counter-clockwise) to decrease oil pressure. When the valve has been satisfactorily adjusted turn both the locknut and the crown nut until the sealing surfaces are in contact. First tighten the locknut, then the crown nut through an angle of 135°. After all is tightened, secure with safety wire.

**4. CYLINDERS.** It is recommended that as a field operation, cylinder maintenance be confined to replacement of the entire assembly. For valve replacement, consult the proper overhaul manual. This should be undertaken only as an emergency measure.

# LYCOMING OPERATOR'S MANUAL

## GO-480, IGO-480, GSO-480, IGSO-480 SERIES SECTION 5

### *a. Removal of Cylinder Assembly -*

- (1) Remove exhaust manifold.
- (2) Remove rocker box drain tube, intake pipe, baffle and any clips that might interfere with the removal of the cylinder.
- (3) Disconnect ignition cables and remove the bottom spark plug.
- (4) Remove rocker box cover and rotate crankshaft until piston is approximately at top center of the compression stroke. This is indicated by a positive pressure inside of cylinder tending to push thumb off of bottom spark plug hole.
- (5) Slide valve rocker shafts from cylinder head and remove the valve rockers. Valve rocker shafts can be removed when the cylinder is removed from the engine. Remove rotator cap from exhaust valve stem.
- (6) Remove push rods by grasping ball end and pulling rod out of shroud tube. Detach shroud tube spring and lock plate and pull shroud tubes through holes in cylinder head.

### *NOTE*

*The hydraulic tappets, push rods, rocker arms and valves must be assembled in the same location from which they were removed.*

- (7) Remove cylinder base nuts and hold down plates (where employed) then remove cylinder by pulling directly away from crankcase. Be careful not to allow the piston to drop against the crankcase, as the piston leaves the cylinder.

*b. Removal of Piston from Connecting Rod -* Remove the piston pin plugs. Insert piston pin puller through piston pin, assemble puller nut; then proceed to remove piston pin. Do not allow connecting rod to rest on the cylinder bore of the crankcase. Support the connecting rod with heavy rubber band, discarded cylinder base oil ring seal, or any other non-marring method.

# LYCOMING OPERATOR'S MANUAL

## SECTION 5 GO-480, IGO-480, GSO-480, IGSO-480 SERIES

*c. Removal of Hydraulic Tappet Sockets and Plunger Assemblies* - It will be necessary to remove and bleed the hydraulic tappet plunger assembly so that dry tappet clearance can be checked when the cylinder assembly is reinstalled. This is accomplished in the following manner:

(1) Remove the hydraulic tappet push rod socket by inserting the forefinger into the concave end of the socket and withdrawing. If the socket cannot be removed in this manner, it may be removed by grasping the edge of the socket with a pair of needle nose pliers. However, care must be exercised to avoid scratching the socket.

(2) To remove the hydraulic tappet plunger assembly, use the special Avco Lycoming service tool. In the event that the tool is not available, the hydraulic tappet plunger assembly may be removed by a hook in the end of a short piece of lockwire, inserting the wire so that the hook engages the spring of the plunger assembly. Draw the plunger assembly out of the tappet body by gently pulling the wire.

### CAUTION

*Never use a magnet to remove hydraulic plunger assemblies from the crankcase. This can cause the check ball to remain off its seat, rendering the unit inoperative.*

*d. Assembly of Hydraulic Tappet Plunger Assemblies* - To assemble the unit, unseat the ball by inserting a thin clean wire through the oil inlet hole. With the ball off its seat, insert the plunger and twist clockwise so that the spring catches. All oil must be removed before the plunger is inserted.

*e. Assembly of Cylinder and Related Parts* - Rotate the crankshaft so that the connecting rod of the cylinder being assembled is at the top center of compression stroke. This can be checked by placing two fingers on the intake and exhaust tappet bodies. Rock crankshaft back and forth over top center. If the tappet bodies do not move the crankshaft is on the compression stroke.

(1) Place each plunger assembly in its respective tappet body and assemble the socket on top of plunger assembly.

# LYCOMING OPERATOR'S MANUAL

## GO-480, IGO-480, GSO-480, IGSO-480 SERIES SECTION 5

(2) Assemble piston with rings so that the number stamped on the piston pin boss is toward the front of the engine. The piston pin should be a handpush fit. If difficulty is experienced in inserting the piston pin, it is probably caused by carbon or burrs in the piston pin hole. During assembly, always use a generous quantity of oil, both in the piston pin hole and on the piston pin.

(3) Assemble one piston pin plug at each end of the piston pin and place a new rubber oil seal ring around the cylinder skirt. Coat piston and rings and the inside of the cylinder generously with oil.

(4) Using a piston ring compressor, assemble the cylinder over the piston so that the intake port is at the bottom of the engine. Push the cylinder all of the way on, catching the ring compressor as it is pushed off.

### NOTE

*Before installing cylinder hold-down nuts, lubricate crankcase through stud threads with any one of the following lubricants, or combination of lubricants.*

1. 90% SAE 50W engine oil and 10% STP.
2. Parker Thread Lube.
3. 60% SAE 30 engine oil and 40% Parker Thread Lube.

(5) Assemble hold-down plates (where applicable) and cylinder base hold-down nuts and tighten as directed in the following steps:

### NOTE

*At any time a cylinder is replaced, it is necessary to retorque the thru-studs on the cylinder on the opposite side of the engine.*

(a) (*Engines using hold-down plates*) Install shims between cylinder base hold-down plates and cylinder barrel, as directed in figure 5-2, and tighten 1/2 inch hold-down nuts to 300 inch lbs. (25 foot lbs.) torque, using the sequence shown in figure 5-2.

(b) Remove shims, and using the same sequence, tighten the 1/2 inch cylinder base nuts, to 600 in. lbs. (50 foot lbs.) torque.

### NOTE

*Cylinder assemblies not using hold-down plate are tightened in the same manner as above omitting the shims.*

# LYCOMING OPERATOR'S MANUAL

## SECTION 5 GO-480, IGO-480, GSO-480, IGSO-480 SERIES

(c) Tighten the 3/8 inch hold-down nuts to 300 inch lbs. (25 foot lbs.) torque. Sequence of tightening is optional.

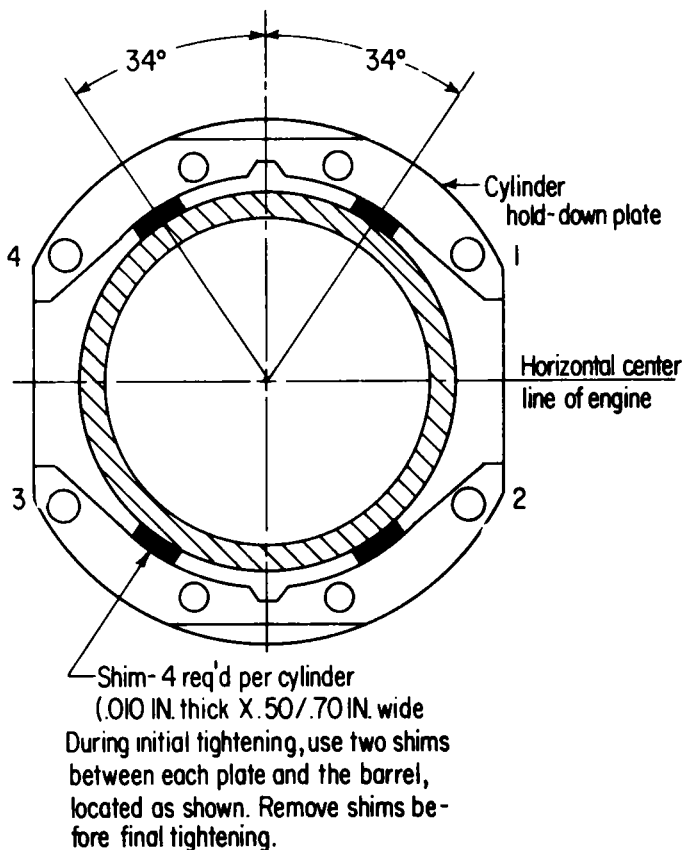

Figure 5-2. Location of Shims Between Cylinder Barrel and Hold-Down Plates (where applicable) and Sequence of Tightening Cylinder Base Hold-Down Nuts

# LYCOMING OPERATOR'S MANUAL

## GO-480, IGO-480, GSO-480, IGSO-480 SERIES SECTION 5

(d) As a final check, hold the torque wrench on each nut for about five seconds. If the nut does not turn, it may be presumed to be tightened to correct torque.

### CAUTION

*After all cylinder base nuts have been tightened, remove any nicks in the cylinder fins by filing or burring.*

(6) Install new shroud tube oil seals on both ends of shroud tube. Install shroud tube and lock in place as required for type of cylinder.

(7) Assemble each push rod in its respective shroud tube, and assemble each rocker in its respective position by placing rocker between bosses and sliding valve rocker shaft in place to retain rocker. Before installing exhaust valve rocker, place rotator cap over end of exhaust valve stem.

(8) Be sure that the piston is at top center of compression stroke and that both valves are closed. Check clearance between the valve stem tip and the valve rocker. In order to check this clearance, place the thumb of one hand on the valve rocker directly over the end of the push rod and push down so as to compress the hydraulic tappet spring. While holding the spring compressed, the valve clearance should be between .028 and .080 inch. If clearance does not come within these limits, remove the push rod and insert a longer or shorter push rod, as required to correct clearance.

### NOTE

*Inserting a longer push rod will decrease the valve clearance.*

(9) Install intercylinder baffles, rocker box covers, intake pipes, rocker box drain tubes and exhaust manifold.

# LYCOMING OPERATOR'S MANUAL

## TROUBLE—SHOOTING

	Page
Failure of Engine to Start . . . . .	.6-1
Failure of Engine to Idle Properly . . . . .	.6-2
Low Power and Uneven Running . . . . .	.6-3
Failure of Engine to Develop Full Power . . . . .	.6-3
Rough Engine . . . . .	.6-4
Low Oil Pressure . . . . .	.6-4
High Oil Temperature . . . . .	.6-5
Excessive Oil Consumption . . . . .	.6-5



# LYCOMING OPERATOR'S MANUAL

GO-480, IGO-480, GSO-480, IGSO-480 SERIES SECTION 6

## SECTION 6

### TROUBLE--SHOOTING

Experience has proven that the best method of trouble-shooting is to decide on the various causes of a given trouble and then to eliminate causes one by one, beginning with the most probable. The following charts list some of the more common troubles, which may be encountered in maintaining engines and turbochargers; their probable causes and remedies.

#### 1. TROUBLE-SHOOTING--ENGINE.

TROUBLE	PROBABLE CAUSE	REMEDY
Failure of Engine to Start	Lack of fuel	Check fuel system for leaks. Fill fuel tank. Clean dirty lines, strainers or fuel valves.
	Overpriming	Leave ignition "off" and mixture control in "Idle Cut-Off", open throttle and "unload" engine by cranking for a few seconds. Turn ignition switch on and proceed to start in a normal manner.
	Defective spark plugs	Clean and adjust or replace spark plugs.
	Defective ignition wire	Check with electric tester, and replace any defective wires.
	Defective battery	Replace with charged battery.

# LYCOMING OPERATOR'S MANUAL

## SECTION 6 GO-480, IGO-480, GSO-480, IGSO-480 SERIES

TROUBLE	PROBABLE CAUSE	REMEDY
Failure of Engine to Start (Cont.)	Improper operation of magneto breaker	Clean points. Check internal timing of magnetos.
	Lack of sufficient fuel flow	Disconnect fuel line and check fuel flow.
	Water in fuel injector or carb.	Drain fuel injector or carburetor and fuel lines.
	Internal failure	Check oil screens for metal particles. If found, complete overhaul of the engine may be indicated.
Failure of Engine to Idle Properly	Incorrect idle mixture	Adjust mixture.
	Leak in induction system	Tighten all connections in the induction system. Replace any parts that are defective.
	Incorrect idle adjustment	Adjust throttle stop to obtain correct idle.
	Uneven cylinder compression	Check condition of piston rings and valve seats.
	Faulty ignition system	Check entire ignition system.
	Insufficient fuel pressure	Adjust fuel pressure.
	Leak in air bleed nozzle balance line	Check connection and replace if necessary.
	Plugged fuel injector nozzle	Clean or replace nozzle.
Flow divider fitting plugged	Clean fitting.	

## LYCOMING OPERATOR'S MANUAL

GO-480, IGO-480, GSO-480, IGSO-480 SERIES      SECTION 6

TROUBLE	PROBABLE CAUSE	REMEDY
Low Power and Uneven Running	Mixture too rich; indicated by sluggish engine operation, red exhaust flame at night. Extreme cases indicated by black smoke from exhaust	Readjustment of fuel injector or carburetors by authorized personnel is indicated.
	Mixture too lean; indicated by overheating or back-firing	Check fuel lines for dirt or other restrictions. Readjustment of fuel injector or carburetor by authorized personnel is indicated.
	Leaks in induction system	Tighten all connections. Replace defective parts.
	Defective spark plugs	Clean and gap or replace spark plugs.
	Improper fuel	Fill tank with fuel of recommended grade.
	Magneto breaker points not working properly	Clean points. Check internal timing of magnetos.
	Defective ignition wire	Check wire with electric tester. Replace defective wire.
	Defective spark plug terminal connectors	Replace connectors on spark plug wire.
	Plugged fuel injector nozzle	Clean or replace nozzle.
	Failure of Engine to Develop Full Power	Leak in induction system

## LYCOMING OPERATOR'S MANUAL

### SECTION 6 GO-480, IGO-480, GSO-480, IGSO-480 SERIES

TROUBLE	PROBABLE CAUSE	REMEDY
Failure of Engine to Develop Full Power (Cont.)	Plugged fuel injector nozzle	Clean or replace nozzle.
	Throttle lever out of adjustment	Adjust throttle lever.
	Improper fuel flow	Check strainer, gage and flow at fuel line.
	Restriction in air scoop	Examine air scoop and remove restrictions.
	Improper fuel	Drain and refill tank with recommended fuel.
	Faulty ignition	Tighten all connections. Check system with tester. Check ignition timing.
Rough Engine	Cracked engine mount	Replace or repair mounting.
	Defective mounting bushings	Install new mounting bushings.
	Uneven compression	Check compression.
	Plugged fuel injector nozzle	Clean or replace nozzle
Low Oil Pressure	Insufficient oil	Fill sump to proper level with recommended oil.
	Air lock or dirt in relief valve	Remove and clean oil pressure relief valve.
	Leak in suction line or pressure line	Check gasket between accessory housing and crankcase.
	High oil temperature	See "High Oil Temperature" in "Trouble" column.
	Defective pressure gage	Replace.

# LYCOMING OPERATOR'S MANUAL

## GO-480, IGO-480, GSO-480, IGSO-480 SERIES SECTION 6

TROUBLE	PROBABLE CAUSE	REMEDY
Low Oil Pressure (Cont.)	Stoppage in oil pump intake passage	Check line for obstruction. Clean suction strainer.
High Oil Temperature	Insufficient air cooling	Check air inlet and outlet for deformation or obstruction.
	Insufficient oil supply	Fill oil sump to proper level with specified oil.
	Low grade of oil	Replace with oil conforming to specifications.
	Clogged oil lines or strainers	Remove and clean oil strainers.
	Excessive blow-by	Usually caused by worn or stuck rings.
	Failing or failed bearing	Examine sump for metal particles. If found, overhaul of engine is indicated.
Excessive Oil Consumption	Defective temperature gage	Replace gage.
	Low grade of oil	Fill tank with oil conforming to specification.
	Failing or failed bearings	Check sump for metal particles.
	Worn piston rings	Install new rings.
	Incorrect installation of piston rings	Install new rings.

## LYCOMING OPERATOR'S MANUAL

### SECTION 6 GO-480, IGO-480, GSO-480, IGSO-480 SERIES

TROUBLE	PROBABLE CAUSE	REMEDY
Excessive Oil Consumption (Cont.)	Failure of rings to seat (new nitrided cylinders)	Use mineral base oil. Climb to cruise altitude at full power and operate at 75% cruise power setting until oil consumption stabilizes.
High Fuel Flow Indicated on Fuel Gage	Plugged fuel injector nozzle	Clean or replace nozzle.

## INSTALLATION

Page

Unpacking . . . . .	7-1
Preparation of Engine for Installation . . . . .	7-1
<b>Inspection of Engine Mounting</b> . . . . .	7-2
<b>Attaching Engine to Mounts</b> . . . . .	7-2
<b>Oil and Fuel Line Connections</b> . . . . .	7-2
<b>Propeller Installation</b> . . . . .	7-2
Corrosion Prevention in Engines	
<b>Installed in Inactive Aircraft</b> . . . . .	7-3
Installation Drawings . . . . .	7-5

# LYCOMING OPERATOR'S MANUAL

GO-480, IGO-480, GSO-480, IGSO-480 SERIES SECTION 7

## SECTION 7

### INSTALLATION

#### 1. UNPACKING.

*General* - Subject aircraft engines are securely packed for shipment, one to the crate, in a horizontal position. The attaching parts are packed in a separate carton within the engine crate.

*Unpacking* - Open shipping crate. Remove inner carton containing loose shipping parts. Attach lifting, cable to lifting eyes. With a suitable hoist, take up the slack cable. Remove the bolts and lift engine clear of shipping crate. With the engine in this position, remove the bottom plugs from the cylinders. Assemble spark plugs and clean exterior of engine thoroughly.

**2. PREPARATION OF ENGINE FOR INSTALLATION.** Before installing an engine that has been prepared for storage, remove all dehydrator plugs, bags of dessicant and preservative oil from the engine. Preservation oil can be removed by removing the bottom spark plugs and turning the crankshaft three or four revolutions by hand. The preservative oil will then drain through the spark plug holes. Draining will be facilitated if the engine is tilted from side to side during the above operation. Preservative oil which has accumulated in the sump can be drained by removing the oil sump plug. Engines that have been stored in a cold place should be removed to an environment of at least 70°F. (21°C.) for a period of 24 hours before preservative oil is drained from the cylinders. If this is not possible, heat the cylinders with heat lamps before attempting to drain the engine.

After the oil sump has been drained, the plug should be replaced and safety-wired, and the sump or external tank refilled with lubricating oil. The crankshaft should again be turned several revolutions to saturate the interior of the engine with the clean oil. When installing spark plugs, make sure that they are clean, if not wash them in clean petroleum solvent. Of course, there will be a small amount of preservative oil remaining in the engine, but this can cause no harm. However, after twenty-five hours of operation, the lubricating oil should be drained while the engine is hot. This will remove any residual preservative oil that may have been present.



# LYCOMING OPERATOR'S MANUAL

## SECTION 7 GO-480, IGO-480, GSO-480, IGSO-480 SERIES

### CAUTION

*Do not rotate the crankshaft of an engine containing preservative oil before removing the spark plugs, because if the cylinders contain any appreciable amount of the mixture, the resulting action, known as hydraulic, will cause damage to the engine. Also, any contact of the preservative oil with painted surfaces should be avoided.*

*General* - Should any of the dehydrator plugs, containing crystals of silica-gel or similar material, be broken during their term of storage or upon their removal from the engine, and if any of the contents should fall into the engine, that portion of the engine must be disassembled and thoroughly cleaned before using the engine. The oil strainers should be removed and cleaned in gasoline or some other hydrocarbon solvent. If applicable, the fuel drain screen located in the fuel inlet of the carburetor or fuel injector should also be removed and cleaned in a hydrocarbon solvent. The operator should also note if any valves are sticking. If they are, this condition can be eliminated by coating the valve stem generously with a mixture of gasoline and lubrication oil.

*Inspection of Engine Mounting* - If the airplane is one from which an engine has been removed, make sure that the engine mount is not bent or damaged by distortion or misalignment as this can produce abnormal stresses with the engine.

*Attaching Engine to Mounts* - See airframe manufacturer's recommendations for method of mounting the engine.

*Oil and Fuel Line Connections* - The oil and fuel line connections are called out on the accompanying installation drawings.

*Propeller Installation* - Consult the airframe manufacturer for information relative to propeller installation.

# LYCOMING OPERATOR'S MANUAL

GO-480, IGO-480, GSO-480, IGSO-480 SERIES SECTION 7

## *CORROSION PREVENTION IN ENGINES INSTALLED IN INACTIVE AIRCRAFT*

Corrosion can occur, especially in new or overhauled engines, on cylinder walls of engines that will be inoperative for periods as brief as two days. Therefore, the following preservation procedure is recommended for inactive engines and will be effective in minimizing the corrosion condition for a period up to thirty days.

### *NOTE*

*Ground running the engine for brief periods of time is not a substitute for the following procedure; in fact, the practice of ground running will tend to aggravate rather than minimize this corrosion condition.*

- a. As soon as possible after the engine is stopped, move the aircraft into the hangar, or other shelter where the preservation process is to be performed.
- b. Remove sufficient cowling to gain access to the spark plugs and remove both spark plugs from each cylinder.
- c. Spray the interior of each cylinder with approximately (2) ounces of corrosion preventive oil while cranking the engine about five (5) revolutions with the starter. The spray gun nozzle may be placed in either of the spark plug holes.

### *NOTE*

*Spraying should be accomplished using an airless spray gun (Spraying Systems Co., "Gunjet" Model 24A-8395, or equivalent). In the event an airless spray gun is not available, personnel should install a moisture trap in the air line of a conventional spray gun and be certain oil is hot at the nozzle before spraying cylinders.*

- d. With the crankshaft stationary, again spray each cylinder through the spark plug holes with approximately two ounces of corrosion preventive oil. Assemble spark plugs and do not turn crankshaft after cylinders have been sprayed.

## LYCOMING OPERATOR'S MANUAL

### SECTION 7 GO-480, IGO-480, GSO-480, IGSO-480 SERIES

The corrosion preventive oil to be used in the foregoing procedure should conform to specification MIL-L-6529, Type 1, heated to 200°F./220°F. (93°C./104°C.) spray nozzle temperature. It is not necessary to flush preservative oil from the cylinder prior to flying the aircraft. The small quantity of oil coating the cylinders will be expelled from the engine during the first few minutes of operation.

#### NOTE

*Oils of the type mentioned are to be used in Avco Lycoming aircraft engines for corrosion prevention only, and not for lubrication. See the latest edition of Avco Lycoming Service Instruction No. 1014 and Service Bulletin No. 318 for recommended lubricating oil.*

# LYCOMING OPERATOR'S MANUAL

GO-480, IGO-480, GSO-480, IGSO-480 SERIES SECTION 7

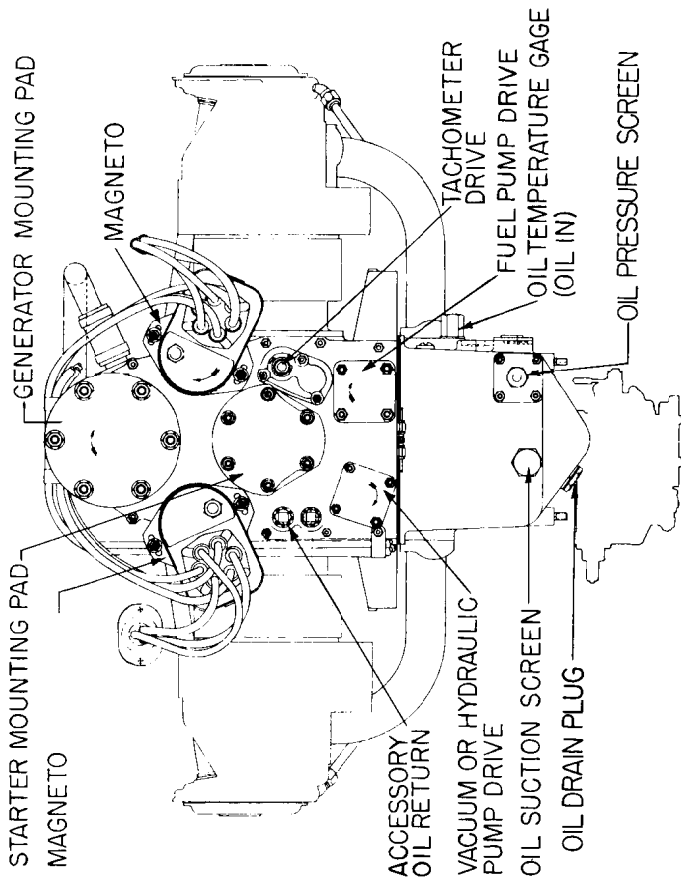

Figure 7-1. Rear View, Typical Engine - Rear Mounted Accessories

# LYCOMING OPERATOR'S MANUAL

## SECTION 7 GO-480, IGO-480, GSO-480, IGSO-480 SERIES

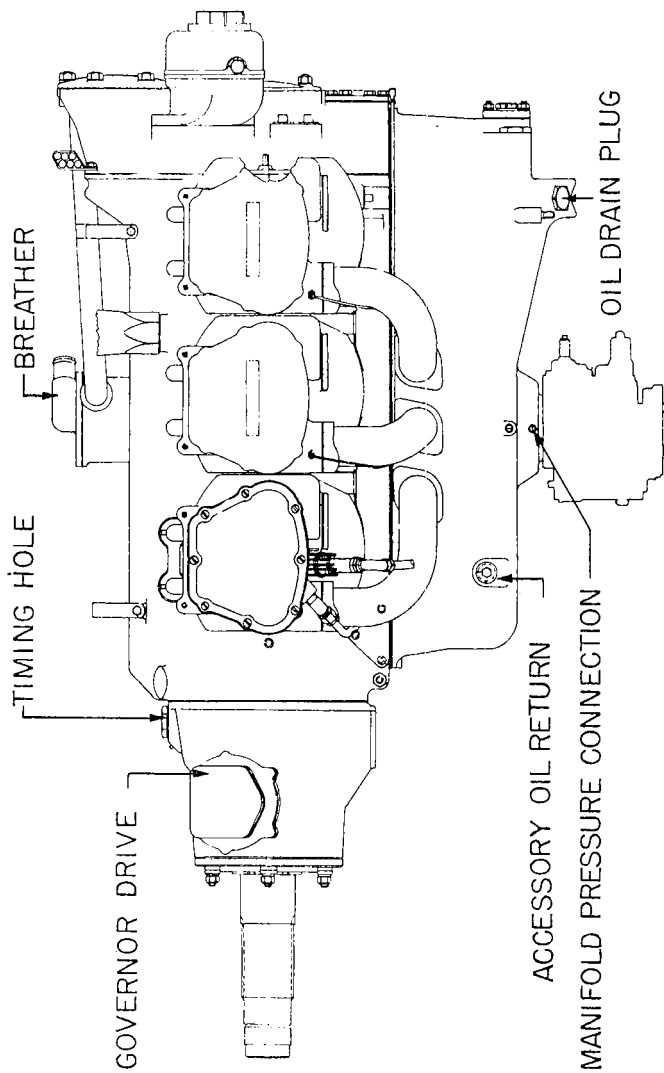

Figure 7-2. Side View, Typical Engine - Rear Mounted Accessories

# LYCOMING OPERATOR'S MANUAL

## GO-480, IGO-480, GSO-480, IGSO-480 SERIES SECTION 7

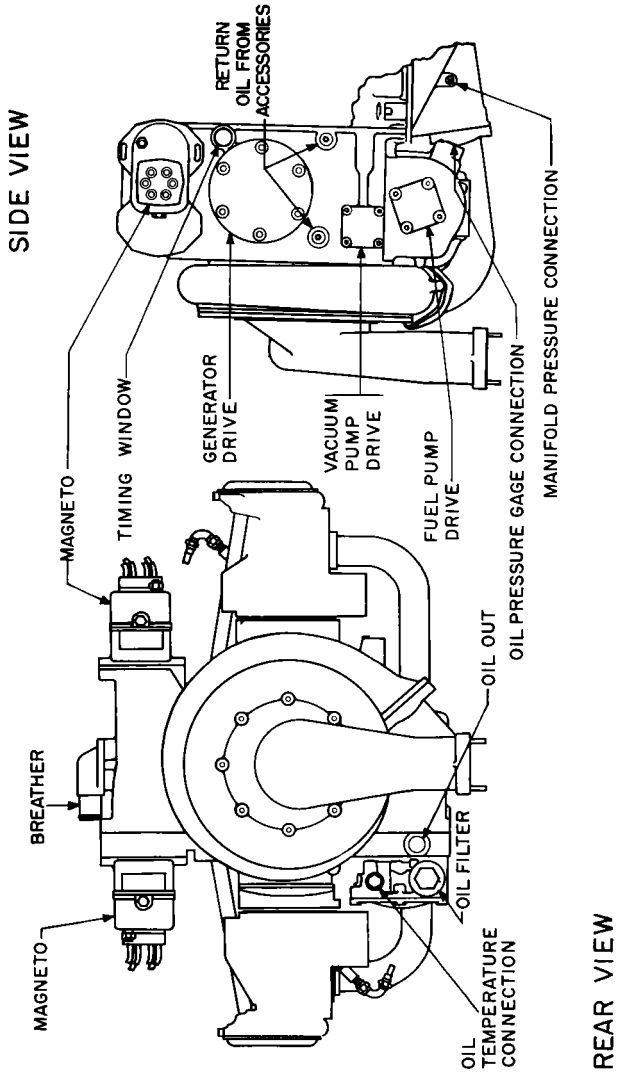

Figure 7-3. Rear and Right Side View, Typical Engine - Side Mounted Accessories

# LYCOMING OPERATOR'S MANUAL

## SECTION 7 GO-480, IGO-480, GSO-480, IGSO-480 SERIES

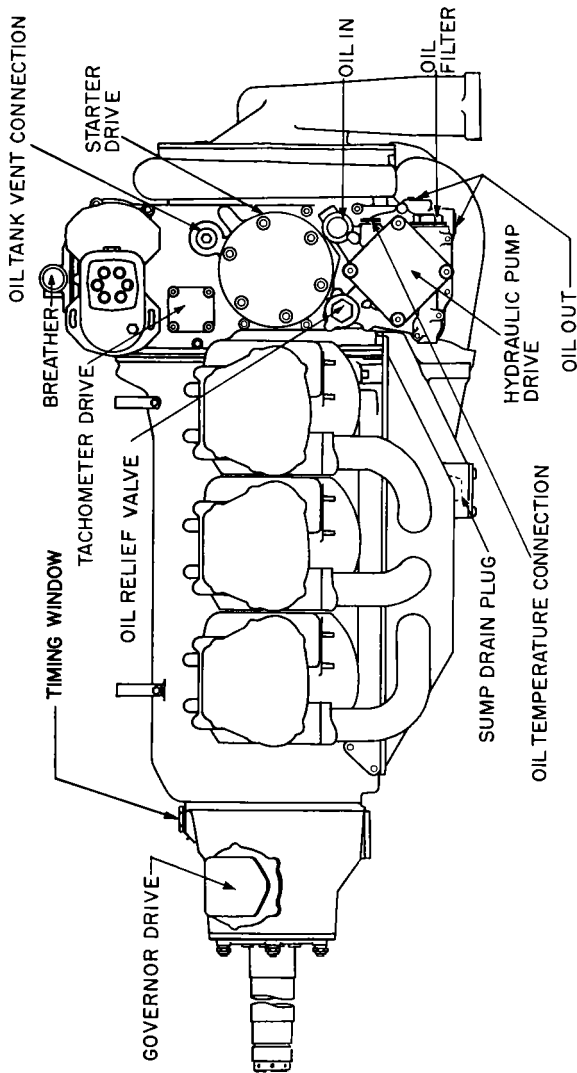

Figure 7-4. Left Side View, Typical Engine - Side Mounted Accessories

# LYCOMING OPERATOR'S MANUAL

## GO-480, IGO-480, GSO-480, IGSO-480 SERIES SECTION 7

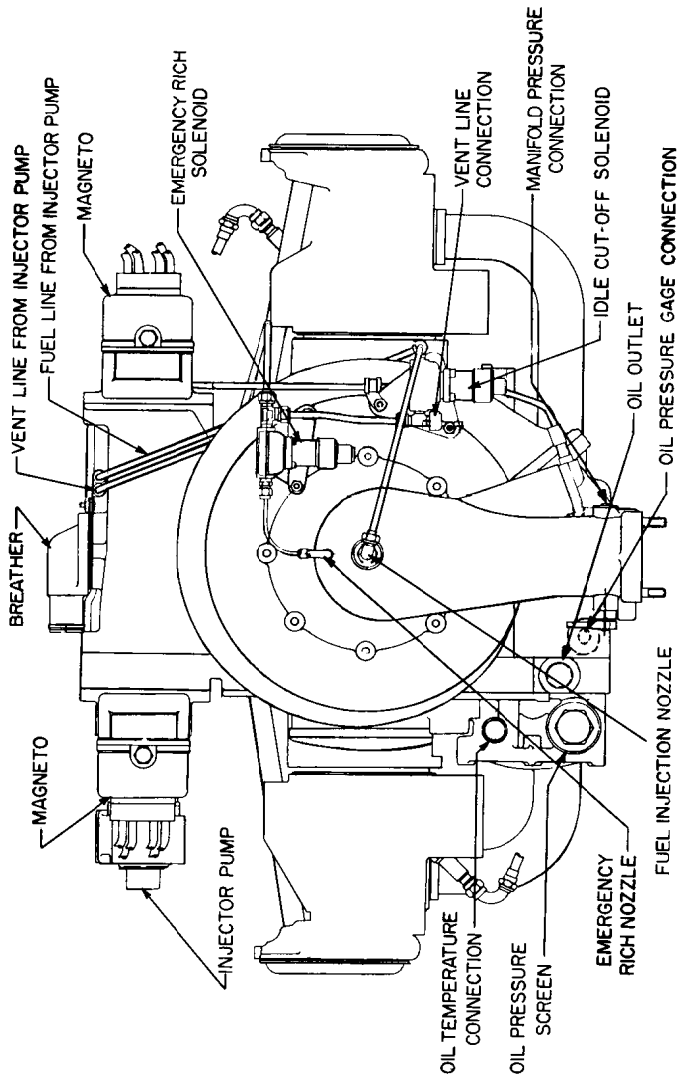

Figure 7-5. Rear View, IGSO-480 - Simmonds Injector



# LYCOMING OPERATOR'S MANUAL

## SECTION 7 GO-480, IGO-480, GSO-480, IGSO-480 SERIES

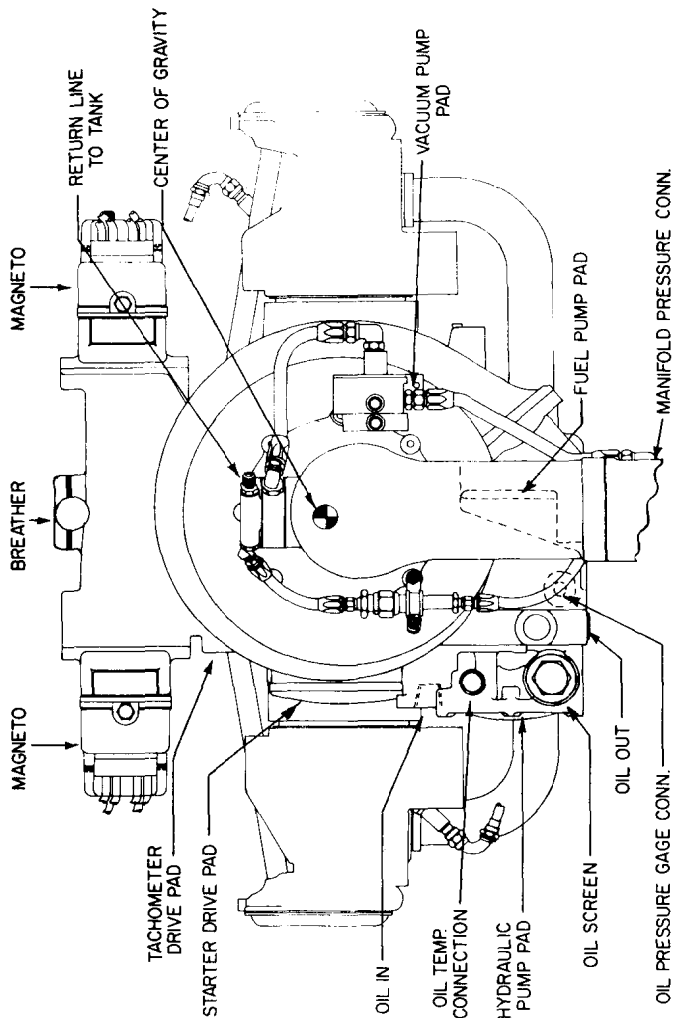

Figure 7-6. Rear View, IGSO-480 - Bendix Injector

# LYCOMING OPERATOR'S MANUAL

## TABLES

	Page
Table of Limits . . . . .	.8-1
Ground Run After Top Overhaul . . . . .	.8-2
Flight Test After Top Overhaul . . . . .	.8-3
Full Throttle HP at Altitude . . . . .	.8-4
Table of Speed Equivalents . . . . .	.8-4
Centigrade - Fahrenheit Conversion Table . . . . .	.8-5
Inch Fraction Conversions . . . . .	.8-6

**SECTION 8**

**TABLES**

FOR TIGHTENING TORQUE RECOMMENDATIONS AND INFORMATION CONCERNING TOLERANCES AND DIMENSIONS THAT MUST BE MAINTAINED IN AVCO LYCOMING AIRCRAFT ENGINES, CONSULT LATEST EDITION OF SPECIAL SERVICE PUBLICATION NO. SSP1776.

CONSULT LATEST EDITION OF SERVICE INSTRUCTION NO. 1029 AND NO. 1150 FOR INFORMATION PERTINENT TO CORRECTLY INSTALLING CYLINDER ASSEMBLY.

**SECTION 8 GO-480, IGO-480, GSO-480, IGSO-480 SERIES**

<b>FIXED WING ONLY</b>														
<b>GROUND RUN AFTER TOP OVERHAUL OR CYLINDER CHANGE WITH NEW RINGS (DO NOT USE AFTER MAJOR OVERHAUL)</b>														
Type Aircraft _____					Registration No. _____									
Aircraft No. _____					Aircraft No. _____									
Owner _____					Engine Model _____ S/N _____									
Date _____					Run-Up By _____									
<b>GROUND RUN</b>														
Time	RPM	MAP		Temperature		Pressure		Temperature		Fuel Flow				
		L.oil	R.oil	L.cy	R.cy	L.oil	R.oil	L.fuel	R.fuel	L.carb	R.carb	Air	Left	Right
5 min	1000													
10 min	1200													
10 min	1300													
5 min	1500													
5 min	1600													
5 min	1700													
5 min	1800													
Mag. Check _____					Adjustment Required _____					After Completion of Ground Run				
Power Check _____										1. Visually inspect engine(s) 2. Check oil level(s)				
Idle Check _____														

1. Avoid dusty location and loose stones.
2. Head aircraft into wind.
3. All cowlings should be in place, cowl flaps open.
4. Accomplish ground run in full flat pitch.
5. Never exceed 200°F. oil temperature.
6. If cylinder head temperatures reach 400°F., shut down and allow engine to cool before continuing.

# LYCOMING OPERATOR'S MANUAL

GO-480, IGO-480, GSO-480, IGSO-480 SERIES      SECTION 8

## FLIGHT TEST AFTER TOP OVERHAUL OR CYLINDER CHANGE WITH NEW RINGS

1. Test fly aircraft one hour.
2. Use standard power for climb, and at least 75% power for cruise.
3. Make climb shallow and at good airspeed for cooling.
4. Record engine instrument readings during climb and cruise.

Tested by \_\_\_\_\_

### FLIGHT TEST RECORD

Time (Climb) Cruise	MAP		Temperature		Pressure		Temperature		Fuel Flow						
	RPM	L.oil	R.oil	L.cyl	R.cyl	L.oil	R.oil	L.fuel	R.fuel	L.carb	R.carb	Amb.	Air	Left	Right

Adjustments Required After Flight

After Test Flight

1. Make careful visual inspection of engine(s).
2. Check oil level(s).
3. If oil consumption is excessive, (see operator's manual for limits), remove spark plugs and check cylinder barrels for scoring.

# LYCOMING OPERATOR'S MANUAL

## SECTION 8 GO-480, IGO-480, GSO-480, IGSO-480 SERIES

### FULL THROTTLE HP AT ALTITUDE (Normally Aspirated Engines)

<u>Altitude Ft.</u>	<u>% S. L. H. P.</u>	<u>Altitude Ft.</u>	<u>% S. L. H. P.</u>	<u>Altitude Ft.</u>	<u>% S. L. H. P.</u>
0	100	10,000	70.8	19,500	49.1
500	98.5	11,000	68.3	20,000	48.0
1,000	96.8	12,000	65.8	20,500	47.6
2,000	93.6	13,000	63.4	21,000	46.0
2,500	92.0	14,000	61.0	21,500	45.2
3,000	90.5	15,000	58.7	22,000	44.0
4,000	87.5	16,000	56.5	22,500	43.3
5,000	84.6	17,000	54.3	23,000	42.2
6,000	81.7	17,500	53.1	23,500	41.4
7,000	78.9	18,000	52.1	24,000	40.3
8,000	76.2	18,500	51.4	24,500	39.5
9,000	73.5	19,000	50.0	25,000	38.5

### TABLE OF SPEED EQUIVALENTS

<u>Sec./Mi.</u>	<u>M. P. H.</u>	<u>Sec./Mi.</u>	<u>M. P. H.</u>	<u>Sec./Mi.</u>	<u>M. P. H.</u>
72.0	50	24.0	150	14.4	250
60.0	60	22.5	160	13.8	260
51.4	70	21.2	170	13.3	270
45.0	80	20.0	180	12.8	280
40.0	90	18.9	190	12.4	290
36.0	100	18.0	200	12.0	300
32.7	110	17.1	210	11.6	310
30.0	120	16.4	220	11.2	320
27.7	130	15.6	230	10.9	330
25.7	140	15.0	240	10.6	340

**CENTIGRADE-FAHRENHEIT CONVERSION TABLE**

Example: To convert 20°C. to Fahrenheit, find 20 in the center column headed (F-C); then read 68.0°F. in the column (F) to the right. To convert 20°F. to Centigrade; find 20 in the center column and read -6.67°C. in the (C) column to the left.

<u>C</u>	<u>F-C</u>	<u>F</u>	<u>C</u>	<u>F-C</u>	<u>F</u>
-56.7	-70	-94.0	104.44	220	428.0
-51.1	-60	-76.0	110.00	230	446.0
-45.6	-50	-58.0	115.56	240	464.0
-40.0	-40	-40.0	121.11	250	482.0
-34.0	-30	-22.0	126.67	260	500.0
-28.9	-20	-4.0	132.22	270	518.0
-23.3	-10	14.0	137.78	280	536.0
-17.8	0	32.0	143.33	290	554.0
-12.22	10	50.0	148.89	300	572.0
-6.67	20	68.0	154.44	310	590.0
-1.11	30	86.0	160.00	320	608.0
4.44	40	104.0	165.56	330	626.0
10.00	50	122.0	171.11	340	644.0
15.56	60	140.0	176.67	350	662.0
21.11	70	158.0	182.22	360	680.0
26.67	80	176.0	187.78	370	698.0
32.22	90	194.0	193.33	380	716.0
37.78	100	212.0	198.89	390	734.0
43.33	110	230.0	204.44	400	752.0
48.89	120	248.0	210.00	410	770.0
54.44	130	266.0	215.56	420	788.0
60.00	140	284.0	221.11	430	806.0
65.56	150	302.0	226.67	440	824.0
71.00	160	320.0	232.22	450	842.0
76.67	170	338.0	237.78	460	860.0
82.22	180	356.0	243.33	470	878.0
87.78	190	374.0	248.89	480	896.0
93.33	200	392.0	254.44	490	914.0
98.89	210	410.0	260.00	500	932.0

**SECTION 8 GO-480, IGO-480, GSO-480, IGSO-480 SERIES**

**INCH FRACTIONS CONVERSIONS**  
Decimals, Area of Circles and Millimeters

<u>Inch Fraction</u>	<u>Decimal Equiv.</u>	<u>Area Sq. In.</u>	<u>MM. Equiv.</u>	<u>Inch Fraction</u>	<u>Decimal Equiv.</u>	<u>Area Sq. In.</u>	<u>MM. Equiv.</u>
1/64	.0156	.0002	.397	1/2	.5	.1964	12.700
1/32	.0312	.0008	.794	17/32	.5312	.2217	13.494
3/64	.0469	.0017	1.191	35/64	.5469	.2349	13.891
1/16	.0625	.0031	1.587	9/16	.5625	.2485	14.288
3/32	.0937	.0069	2.381	19/32	.5937	.2769	15.081
7/64	.1094	.0094	2.778	39/64	.6094	.2916	15.478
1/8	.125	.0123	3.175	5/8	.625	.3068	15.875
5/32	.1562	.0192	3.969	21/32	.6562	.3382	16.669
11/64	.1719	.0232	4.366	43/64	.6719	.3545	17.065
3/16	.1875	.0276	4.762	11/16	.6875	.3712	17.462
7/32	.2187	.0376	5.556	23/32	.7187	.4057	18.256
15/64	.2344	.0431	5.593	47/64	.7344	.4235	18.653
1/4	.25	.0491	6.350	3/4	.75	.4418	19.050
9/32	.2812	.0621	7.144	25/32	.7812	.4794	19.844
19/64	.2969	.0692	7.540	51/64	.7969	.4987	20.241
5/16	.3125	.0767	7.937	13/16	.8125	.5185	20.637
11/32	.3437	.0928	8.731	27/32	.8437	.5591	21.431
23/64	.3594	.1014	9.128	55/64	.8594	.5800	21.828
3/8	.375	.1105	9.525	7/8	.875	.6013	22.225
13/32	.4062	.1296	10.319	29/32	.9062	.6450	23.019
27/64	.4219	.1398	10.716	59/64	.9219	.6675	23.416
7/16	.4375	.1503	11.112	15/16	.9375	.6903	23.812
15/32	.4687	.1725	11.906	31/32	.9687	.7371	24.606
31/64	.4844	.1842	12.303	63/64	.9844	.7610	25.003